



Nuova C.U.M.E.T.
Milling Tool Holder

Precision in *movement!*

TESTINA PER COPIATURA

Threaded Milling Cutters for Copying



CON REFRIGERAZIONE INTERNA - WITH INTERNAL COOLANT

CODE	D mm	L mm	M ISO	d mm	R mm	Z No	Insert	Vite Screw	Torx Key
TRD0120602	12	18	6	6.5	3.5	2	RD..0701	A25	T07
TRD0150802	15	23	8	8.5	3.5	2	RD..0702		
TRD0160802	16	23	8	8.5	3.5	2			
TRD0160803	16	23	8	8.5	3.5	3			
TRD0201003	20	30	10	10.5	3.5	3			
TRD0201004	20	30	10	10.5	3.5	4			
TRD0251205	25	35	12	12.5	3.5	5			
TRD0321605	32	43	16	17	3.5	5			
TRD0201002	20	30	10	10.5	5	2	RD..1003	A35	T15
TRD0251202	25	35	12	12.5	5	2			
TRD0251203	25	35	12	12.5	5	3			
TRD0321603	32	43	16	17	5	3			
TRD0321604	32	43	16	17	5	4			
TRD0351603	35	43	16	17	5	3			
TRD0351604	35	43	16	17	5	4			
TRD0351605	35	43	16	17	5	5			
TRD0401604	40	43	16	17	5	4			
TRD0421605	42	43	16	17	5	5			



CON REFRIGERAZIONE INTERNA - WITH INTERNAL COOLANT

CODE	D mm	L mm	M ISO	d mm	R mm	Z No	Insert	Vite Screw	Vite Fissaggio Securing Screw	Torx Key
TRD12241202	24	35	12	12.5	6	2	RD..12T3	A38M	-	T15
TRD12251202	25	35	12	12.5	6	2				
TRD12321603	32	43	16	17	6	3				
TRD12351603	35	43	16	17	6	3				
TRD12401604	40	43	16	17	6	4				
TRD12421604	42	43	16	17	6	4				

TESTINA PER COPIATURA

Threaded Milling Cutters for Copying



CON REFRIGERAZIONE INTERNA - WITH INTERNAL COOLANT

CODE	D mm	L mm	M ISO	d mm	R mm	Z No	Insert	Vite Screw	Rondella Lock Washer	Vite Fissaggio Securing Screw	Torx Key
TRD16321602	32	43	16	17	8	2	RD..1604	A45M	R01	A45	T20



CON REFRIGERAZIONE INTERNA - WITH INTERNAL COOLANT

CODE	D mm	L mm	M ISO	d mm	Z No	Insert	Vite Screw	Vite Fissaggio Securing Screw	Torx Key
TXD90100602	10	18	6	6.5	2	XD..0402	A18M	-	T06
TXD90120602	12	18	6	6.5	2			-	
TXD90160802	16	23	8	8.5	2	XD..0602	A25M	-	T07
TXD90201003	20	30	10	10.5	3			-	
TXD90251203	25	35	12	12.5	3			-	
TXD90251204	25	35	12	12.5	4			-	
TXD90351603	35	43	16	17.0	3	XD..1003	A38M	B35	T15
TXD90421604	42	43	16	17.0	4			B35	

TESTINA PER FRESARE

Threaded Milling Cutters



CON REFRIGERAZIONE INTERNA - WITH INTERNAL COOLANT

CODE	D mm	L mm	M ISO	d mm	Z No	Insert	Vite Screw	Vite Fissaggio Securing Screw	Torx Key
TXD95100602	10	18	6	6.5	2	XD..0402	A18M	-	T06
TXD95120602	12	18	6	6.5	2			-	
TXD95150603	15	18	6	6.5	3			-	
TXD95160802	16	23	8	8.5	2	XD..0602	A25M	-	T07
TXD95201003	20	30	10	10.5	3			-	
TXD95251203	25	35	12	12.5	3			-	
TXD95251204	25	35	12	12.5	4			-	
TXD95351605	35	43	16	17	5			-	
TXD95421606	42	43	16	17	6			-	
TXD95351603	35	43	16	17	3	XD..1003	A38M	B35	T15
TXD95401604	40	43	16	17	4				
TXD95421604	42	43	16	17	4				



CON REFRIGERAZIONE INTERNA - WITH INTERNAL COOLANT

CODE	D mm	L mm	P mm	M ISO	d mm	Z No	Insert	Vite Screw	Torx Key
TAP1016080210	16	25	10	8	8.5	2	AP..1003	A26M	T08
TAP1020100310	20	30	10	10	10.5	3			
TAP1025120410	25	35	10	12	12.5	4			
TAP1032160510	32	43	10	16	17	5	AP..1604	A48M	T15
TAP1025120216	25	35	16	12	12.5	2		A49M	
TAP1032160316	32	43	16	16	17	3			

TESTINA PER FRESARE

Threaded Milling Cutters



CON REFRIGERAZIONE INTERNA - WITH INTERNAL COOLANT

CODE	D mm	L mm	H mm	R mm	Z No	Insert	Vite Screw	Torx Key
TVC2232R302	32	48	15	3	2	VC..220530	A45M	T20
TVC2242R303	42	48	15	3	3			



CON REFRIGERAZIONE INTERNA - WITH INTERNAL COOLANT

CODE	D mm	L mm	M ISO	d mm	Z No	Insert	Vite Screw	Torx Key
TRT10160802	16	25	8	8.5	2	**RT1003/T3	A27M	T08IP
TRT10201003	20	30	10	10.5	3			
TRT10251203	25	35	12	12.5	3			
TRT10251204	25	35	12	12.5	4			
TRT10321605	32	43	16	17	5			

CON REFRIGERAZIONE INTERNA - WITH INTERNAL COOLANT

CODE	D mm	L mm	M ISO	d mm	Z No	Insert	Vite Screw	Torx Key
TRT13201002	20	25	10	10.5	2	**RT1304..	A30M	T09IP
TRT13251203	25	30	12	12.5	3			
TRT13321604	32	40	16	17	4			
TRT13351605	35	40	16	17	5			

****FORNIBILI SOLO A RICHIESTA
AVAILABLE ON DEMAND**

TESTINA PER COPIATURA
Threaded Milling for Copy



CODE	D mm	L mm	M ISO	d mm	Insert	Vite Screw	Torx Key
TWPV12060	12	20	6	6.5	WPV..WPB12..	A09M	T15
TWPV16080	16	25	8	8.5	WPV..WPB16..	A10M	T20
TWPV20100	20	30	10	10.5	WPV..WPB20..	A11M	
TWPV25120	25	35	12	12.5	WPV..WPB25..	A12M	T25
TWPV32160	32	45	16	17	WPV..WPB32..	A13M	T30



CODE	D mm	L mm	R mm	M ISO	d mm	Insert	Vite Screw	Torx Key
TWPR12060	12	20	6	6	6.5	WPR12..	A09M	T15
TWPR16080	16	25	8	8	8.5	WPR16..	A10M	T20
TWPR20100	20	30	10	10	10.5	WPR20..	A11M	
TWPR25125	25	35	12.5	12	12.5	WPR25..	A12M	T25
TWPR32160	32	45	16	16	17	WPR32..	A13M	T30

TESTINA PER COPIATURA

Threaded Milling for Copy



CODE	D mm	L mm	R mm	M ISO	d mm	Insert	Vite Screw	Torx Key
TAWR1206R060	12	20	6	6	6.5	AWR12..	C09	T10
TAWR1608R080	16	25	8	8	8.5	AWR16..	C10	T15
TAWR2010R100	20	30	10	10	10.5	AWR20..	C11	T20
TAWR2512R125	25	35	12.5	12	12.5	AWR25..	C12	T25
TAWR3216R160	32	45	16	16	17	AWR32..	C13	T30

TESTINA PER ELEVATI AVANZAMENTI

Milling for High Feed

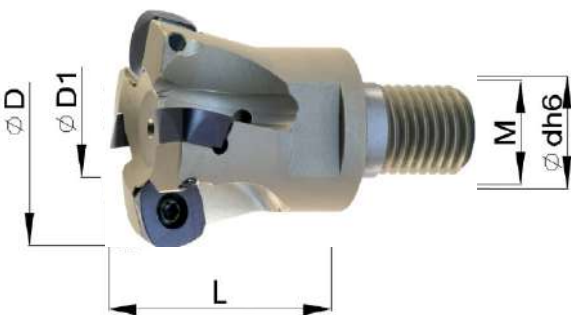

CODE	D mm	D1 mm	L mm	M ISO	d mm	Z No	Insert	Vite Screw	Torx Key
TSD12351603	35	17	40	16	17	3	SD..1205 ZDTN-R15	A49M	T15
TSD12421604	42	24	40	16	17	4		A50M	

PROLUNGHE PER ATTACCHI FILETTATI

Extensions for Milling Cutters Modular Type

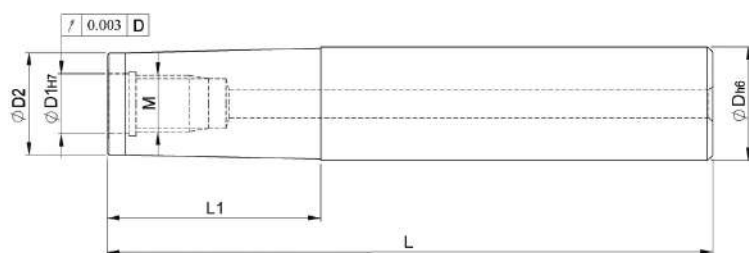

Acciaio - Steel

CODE	D mm	M ISO	L mm	L1 mm	D1 mm	D2 mm
PRG1206160	12	6	160	40	6.5	9.8
PRG1608160	16	8	160	45	8.5	12.8
PRG1608200	16	8	200	10	8.5	14
PRG2010160	20	10	160	50	10.5	17.8
PRG2010250	20	10	250	12	10.5	18
PRG2512160	25	12	160	55	12.5	20.8
PRG2512250	25	12	250	15	12.5	23
PRG3216160	32	16	160	60	17	28.8
PRG3216300	32	16	300	18	17	29

Metallo Duro – Solid Carbide

CODE	D mm	M ISO	L mm	D1 mm
PRGM1106100	11	6	100	6.5
PRGM1106150	11	6	150	6.5
PRGM1206100	12	6	100	6.5
PRGM1206150	12	6	150	6.5
PRGM1508100	15	8	100	8.5
PRGM1508150	15	8	150	8.5
PRGM1508200	15	8	200	8.5
PRGM1608100	16	8	100	8.5
PRGM1608150	16	8	150	8.5
PRGM1608200	16	8	200	8.5
PRGM1910100	19	10	100	10.5
PRGM1910150	19	10	150	10.5
PRGM1910200	19	10	200	10.5
PRGM2010100	20	10	100	10.5
PRGM2010150	20	10	150	10.5
PRGM2010200	20	10	200	10.5
PRGM2412150	24	12	150	12.5
PRGM2412200	24	12	200	12.5
PRGM2412250	24	12	250	12.5
PRGM2512150	25	12	150	12.5
PRGM2512200	25	12	200	12.5
PRGM2512250	25	12	250	12.5
PRGM3216250	32	16	250	17
PRGM3216300	32	16	300	17
PRGM3216400	32	16	400	17

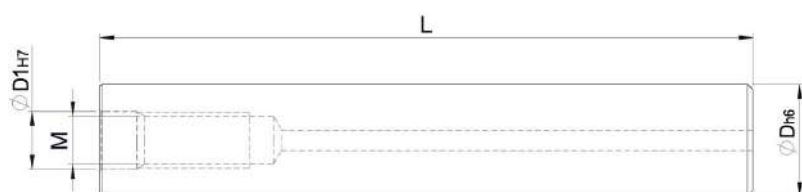

FRESE PER COPIATURA

Threaded Milling for Cop



CORPO IN ACCIAIO – STEEL SHANK

CODE	D mm	L1 mm	L mm	d mm	Insert	Vite Screw	Torx Key
FWPVL0810120	8	40	120	8	WPV-WPB08..	A07M	T08
FWPVL0830120	8	30	120	10			
FWPVL1040120	10	40	120	10	WPV-WPB10..	A08M	T15
FWPVL1035150	10	35	150	12			
FWPVL1250160	12	50	160	12	WPV-WPB12..	A09M	T20
FWPVL1653175	16	53	175	16	WPV-WPB16..	A10M	
FWPVL2061190	20	61	190	20	WPV-WPB20..	A11M	
FWPVL2570190	25	70	190	25	WPV-WPB25..	A12M	T30
FWPVL3280210	32	80	210	32	WPV-WPB32..	A13M	

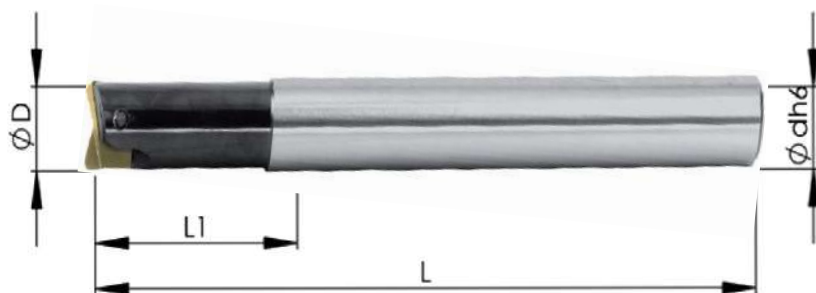

CORPO IN ACCIAIO – STEEL SHANK

CODE	D mm	L1 mm	L mm	d mm	Insert	Vite Screw	Torx Key
FPPHTL1235140	12	35	140	12	PPHT12..	C09	T10
FPPHTL1645170	16	45	170	16	PPHT16..	C10	T15
FPPHTL2055180	20	55	180	20	PPHT20..	C11	T20
FPPHTL2560200	25	60	200	25	PPHT25..	C12	T25

FRESE PER COPIATURA
Threaded Milling for Cop

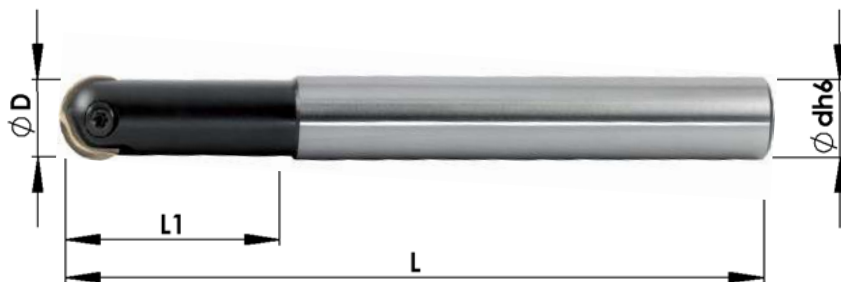

CORPO IN ACCIAIO – STEEL SHANK

CODE	D mm	L1 mm	L mm	d mm	R mm	Insert	Vite Screw	Torx Key
FWPRL0625090	6	25	90	10	3	WPR06..	A00M	T06
FWPRL0810120	8	40	120	8	4	WPR08..	A07M	T08
FWPRL0830120	8	30	120	10	4			
FWPRL1040120	10	40	150	10	5	WPR10..	A08M	T15
FWPRL1035150	10	35	150	12	5			
FWPRL1250160	12	50	160	12	6	WPR12..	A09M	T20
FWPRL1653175	16	53	175	16	8	WPR16..	A10M	
FWPRL2061190	20	61	190	20	10	WPR20..	A11M	T30
FWPRL2570190	25	70	190	25	12.5	WPR25..	A12M	
FWPRL3280210	32	80	210	32	16	WPR32..	A13M	

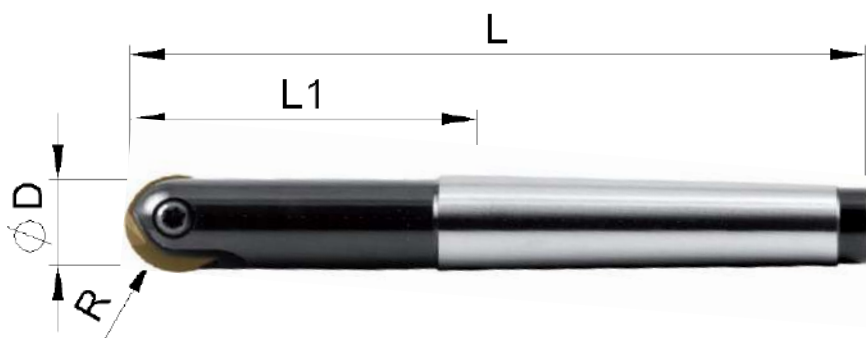

CORPO IN ACCIAIO – STEEL SHANK

CODE	D mm	L1 mm	L mm	R mm	CM	Insert	Vite Screw	Torx Key
FWPRC1655125	16	55	125	8	2	WPR16..	A11M	T20
FWPRC2070140	20	70	140	10	2	WPR20..		
FWPRC2570170	25	70	170	12.5	3	WPR25..	A12M	T25
FWPRC3280190	32	80	190	16	4	WPR32..	A13M	T30
FWPRC3295205	32	95	205	16	4			

FRESE FORANTI

Drilling End Mills

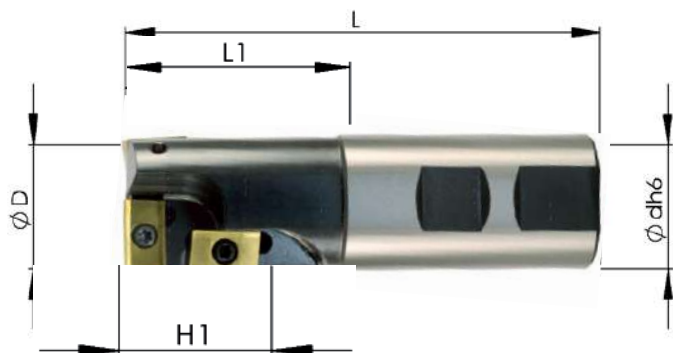

CON REFRIGERAZIONE INTERNA - WITH INTERNAL COOLANT

CODE	D mm	H1 mm	L1 mm	L mm	d mm	Inserts No	Z No	Insert	Vite Screw	Torx Key
FAP102017090	20	17	35	90	20	3	2	AP..1003	A26M	T08
FAP103230130	32	30	50	130	32	3	2	AP..1604	A49M	T15

FRESE PER SPALLAMENTI

Shoulder Milling Cutters



CON REFRIGERAZIONE INTERNA - WITH INTERNAL COOLANT

CODE	D mm	L1 mm	L mm	d mm	Z No	Insert	Vite Screw	Torx Key
FAPS10248001	10	24	80	16	1	AP..1003	A26M	T08
FAPS12248001	12	24	80	16	1			
FAPS14248001	14	24	80	16	1			
FAPS16258502	16	25	85	16	2			
FAPS17258502	17	25	85	16	2			
FAPS18258502	18	25	85	20	2			
FAPS20259003	20	25	90	20	3			
FAPS22259003	22	25	90	20	3			
FAPS24259503	24	25	95	25	3			
FAPS25259503	25	25	95	25	3			
FAPS25259504	25	25	95	25	4			
FAPS32269505	32	26	95	25	5			

FRESE PER SPALLAMENTI

Shoulder Milling Cutters

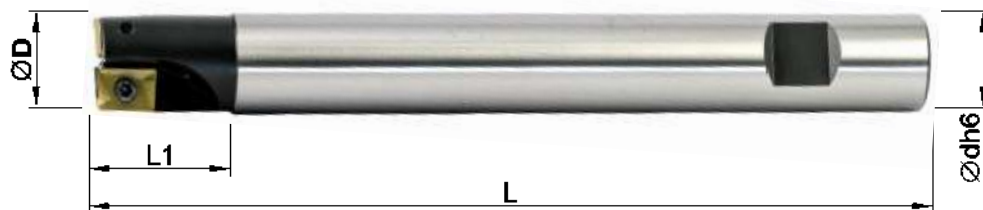

CON REFRIGERAZIONE INTERNA - WITH INTERNAL COOLANT

CODE	D mm	L1 mm	L mm	d mm	Z No	Insert	Vite Screw	Torx Key
FAPSL10241501	10	24	150	16	1	AP..1003	A26M	T08
FAPSL12241501	12	24	150	16	1			
FAPSL16241502	16	24	150	16	2			
FAPSL20251503	20	25	150	20	3			
FAPSL25251504	25	25	150	20	4			
FAPSL32261505	32	26	150	25	5			



CON REFRIGERAZIONE INTERNA - WITH INTERNAL COOLANT

CODE	D mm	L1 mm	L mm	d mm	Z No	Insert	Vite Screw	Torx Key
FAPXL1615200	16	24	200	15	2	AP..1003	A26M	T08
FAPXL1616200	16	24	200	16	2			
FAPXL2019200	20	25	200	19	3			
FAPXL2020200	20	25	200	20	3			
FAPXL2524200	25	25	200	24	3			
FAPXL2525200	25	25	200	25	3			
FAPXL2524201	25	25	200	24	4			
FAPXL2525201	25	25	200	25	4			

FRESE PER SPALLAMENTI

Shoulder Milling Cutters

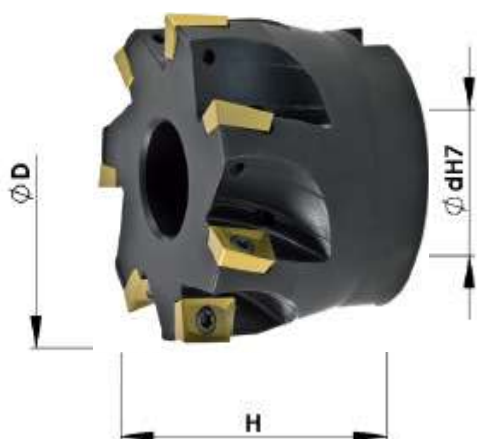

CON REFRIGERAZIONE INTERNA - WITH INTERNAL COOLANT

CODE	D mm	H mm	d mm	Z No	Insert	Vite Screw	Torx Key
SPAP10401606	40	40	16	6	AP..1003	A26M	T08
SPAP10402206	40	40	22	6			
SPAP10502205	50	40	22	5			
SPAP10502207	50	40	22	7			
SPAP10632206	63	40	22	6			
SPAP10632208	63	40	22	8			
SPAP10802711	80	50	27	11			



CON REFRIGERAZIONE INTERNA - WITH INTERNAL COOLANT

CODE	D mm	L1 mm	L mm	d mm	Z No	Insert	Vite Screw	Torx Key
FAP162544100	25	44	100	25	2	AP..1604	A48M	T15
FAP162844100	28	44	100	25	3		A49M	
FAP163250110	32	50	110	32	3			
FAP162540115	40	45	115	32	4			

FRESE PER SPALLAMENTI

Shoulder Milling Cutters



CON REFRIGERAZIONE INTERNA - WITH INTERNAL COOLANT

CODE	D mm	L1 mm	L mm	d mm	Z No	Insert	Vite Screw	Torx Key
FAP16L2560180	25	60	180	20	2	AP..1604	A48M	T15
FAP16L3260180	32	60	180	25	3		A49M	
FAP16L3260180.1	32	60	180	32	3			



CON REFRIGERAZIONE INTERNA - WITH INTERNAL COOLANT

CODE	D mm	L1 mm	L mm	CM	Z No	Insert	Vite Screw	Torx Key
FAP16C3240125	32	40	125	3	3	AP..1604	A49M	T15
FAP16C4048157	40	48	157	4	4			



CON REFRIGERAZIONE INTERNA - WITH INTERNAL COOLANT

CODE	D mm	L mm	d mm	Z No	Insert	Vite Screw	Torx Key
SPAP160401604	40	40	16	4	AP..1604	A49M	T15
SPAP160502205	50	40	22	5			
SPAP160632205	63	40	22	5			
SPAP160632206	63	40	22	6			
SPAP160802706	80	50	27	6			
SPAP161003207	100	50	32	7			
SPAP161254008	125	63	40	8			
SPAP161604010	160	63	40	10			

FRESE PER SPALLAMENTI
Shoulder Milling Cutters



CON REFRIGERAZIONE INTERNA - WITH INTERNAL COOLANT

CODE	D mm	L1 mm	L mm	d mm	Z No	Insert	Vite Screw	Torx Key
FAD152544100	25	44	100	25	2	ADKT1505	A49M	T15
FAD153250110	32	50	110	32	3			
FAD154045115	40	45	115	32	4			

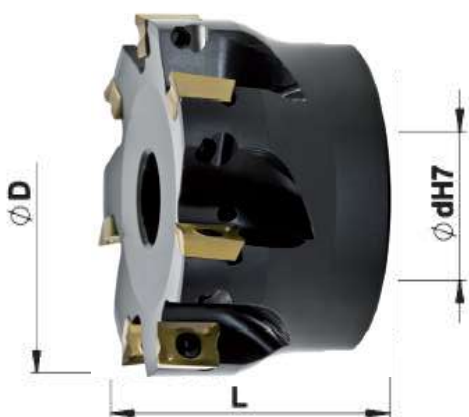

CON REFRIGERAZIONE INTERNA - WITH INTERNAL COOLANT

CODE	D mm	L mm	d mm	Z No	Insert	Vite Screw	Torx Key
SPAD150401604	40	45	16	4	ADKT1505	A49M	T15
SPAD150502205	50	40	22	5			
SPAD150632206	63	40	22	6			
SPAD150802707	80	50	27	7			
SPAD151003208	100	50	32	8			
SPAD151254009	125	63	40	9			

FRESE PER FORTI AVANZAMENTI

High Feed end Mills

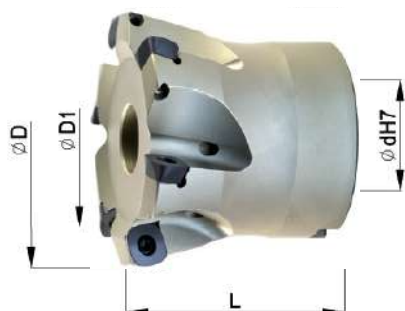

CON REFRIGERAZIONE INTERNA - WITH INTERNAL COOLANT

CODE	D mm	D1 mm	L mm	d mm	Z No	Insert	Vite Screw	Torxl Key
SPSD12F0421604	42	24	45	16	4	SD..1205 ZDTN-R15	A50M	T15
SPSD12F0522205	52	34	50	22	5			
SPSD12F0662705	66	48	50	27	5			
SPSD12F0802706	80	62	70	27	6			
SPSD12F1003208	100	82	70	32	8			

FRESE PER SPALLAMENTI

Shoulder Milling Cutters



CON REFRIGERAZIONE INTERNA - WITH INTERNAL COOLANT

CODE	D mm	L1 mm	L mm	d mm	Z No	Insert	Vite Screw	Torx Key
FRT101630160	16	30	160	16	2	**RT1003/T3	A27M	T08IP
FRT101625160	16	25	160	15	2			
FRT102030200	20	30	200	20	3			
FRT102025200	20	25	200	19	3			
FRT102530200	25	30	200	25	3			
FRT102525200	25	25	200	24	3			

CON REFRIGERAZIONE INTERNA - WITH INTERNAL COOLANT

CODE	D mm	L1 mm	L mm	d mm	Z No	Insert	Vite Screw	Torx Key
FRT13L2030200	20	30	200	20	2	**RT1304..	A30M	T09IP
FRT13L2030200.1	20	30	200	19	2			
FRT13L2535200	25	35	200	25	3			
FRT13L2535200.1	25	35	200	24	3			
FRT13L3240200	32	40	200	32	4			

****FORNIBILI SOLO A RICHIESTA
AVAILABLE ON DEMAND**

FRESE PER SPALLAMENTI
Shoulder Milling Cutters

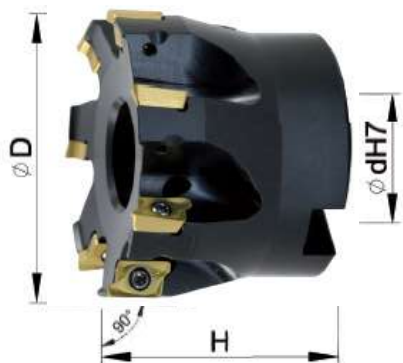

CON REFRIGERAZIONE INTERNA - WITH INTERNAL COOLANT

CODE	D mm	H mm	d mm	Z No	Insert	Vite Screw	Torx Key
SPRT10401606	40	40	16	6	**RT1003/T3	A27M	T08IP
SPRT10502207	50	40	22	7			

CON REFRIGERAZIONE INTERNA - WITH INTERNAL COOLANT

CODE	D mm	H mm	d mm	Z No	Insert	Vite Screw	Torx Key
SPRT13401605	40	40	16	5	**RT1304..	A30M	T09IP
SPRT13502206	50	40	22	6			
SPRT13632207	63	40	22	7			

****FORNIBILI SOLO A RICHIESTA
AVAILABLE ON DEMAND**

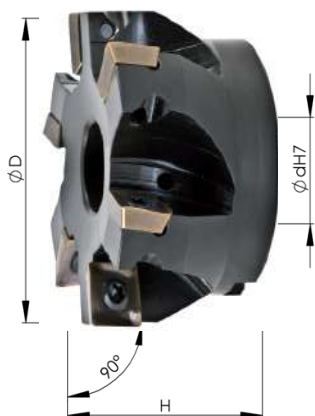

CON REFRIGERAZIONE INTERNA - WITH INTERNAL COOLANT

CODE	D mm	H mm	d mm	Z No	Insert	Vite Screw	Torx Key
SPSD120502205	50	40	22	5	SDHT1204	A49M	T15
SPSD120632206	63	40	22	6			
SPSD120802706	80	50	27	6			
SPSD121003208	100	50	32	8			
SPSD121254009	125	63	40	9			

FRESE PER SPALLAMENTI

Shoulder Milling Cutters

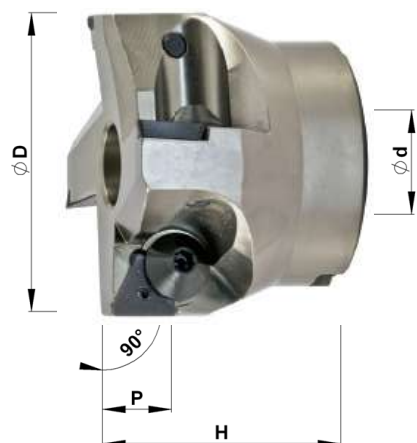

CON REFRIGERAZIONE INTERNA - WITH INTERNAL COOLANT

CODE	D mm	H mm	d mm	Z No	Insert	Vite Screw	Exagonal Key
SPTPK160502203	50	50	22	3	TPK..1603	D01	4mm
SPTPK160632204	63	50	22	4			
SPTPK160802705	80	50	27	5			
SPTPK161003206	100	50	32	6			
SPTPK161254006	125	63	40	6			

CODE	D mm	H mm	d mm	Z No	Insert	Vite Screw	Exagonal Key
SPTPK220632203	63	50	22	3	TPK..2204	D02	5mm
SPTPK220802704	80	50	27	4			
SPTPK221003205	100	50	32	5			
SPTPK221254006	125	63	40	6			
SPTPK221604007	160	63	40	7			



CON REFRIGERAZIONE INTERNA - WITH INTERNAL COOLANT

CODE	D mm	L mm	d mm	H mm	Z No	Insert	Vite Screw	Torx Key
SPVC220421603	42	57	18	15	3	VC..220530	A45M	T20
SPVC220522203	52	57	22	15	3			
SPVC220662704	66	57	27	15	4			
SPVC220802704	80	57	27	15	4			
SPVC221003205	100	55	32	15	5			
SPVC221254006	125	55	40	15	6			

FRESE PER SPALLAMENTI

Shoulder Milling Cutters

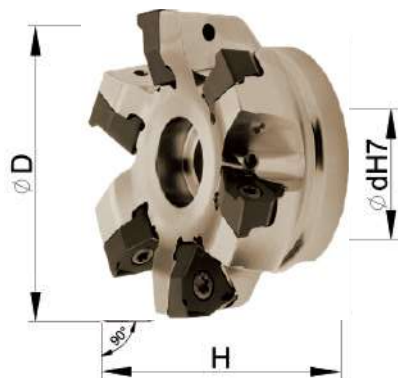

CON REFRIGERAZIONE INTERNA - WITH INTERNAL COOLANT

CODE	D mm	H mm	d mm	Z No	Insert	Vite Screw	Torx Key
SPXN08502204	50	40	22	4	XNEX 080608	A50M	T15
SPXN08502205	50	40	22	5			
SPXN08632205	63	40	22	5			
SPXN08632206	63	40	22	6			
SPXN08802706	80	50	27	6			
SPXN08802707	80	50	27	7			

FRESE PER SPIANATURE

Shoulder Milling Cutters

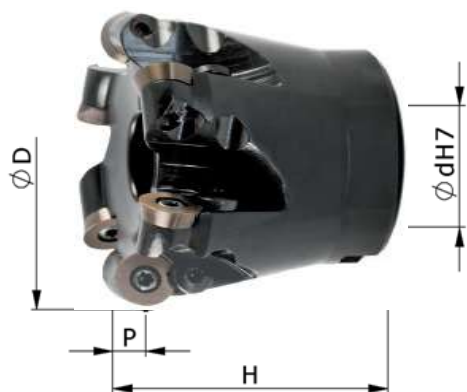

CON REFRIGERAZIONE INTERNA - WITH INTERNAL COOLANT

CODE	D mm	H mm	d mm	P mm	Z No	Insert	Vite Screw	Securing Screw	Torx Key
SPRD12T0401604	40	40	16	6	4	RD..12T3	A38M	B35	T15
SPRD12T0502205	50	50	22	6	5				
SPRD12T0522204	52	50	22	6	4				
SPRD12T0522205	52	50	22	6	5				
SPRD12T0632206	63	50	22	6	6				
SPRD12T0662706	66	50	27	6	6				
SPRD12T0802706	80	50	27	6	6				
SPRD12T0802707	80	50	27	6	7				

FRESE PER SPIANATURE

Shoulder Milling Cutters

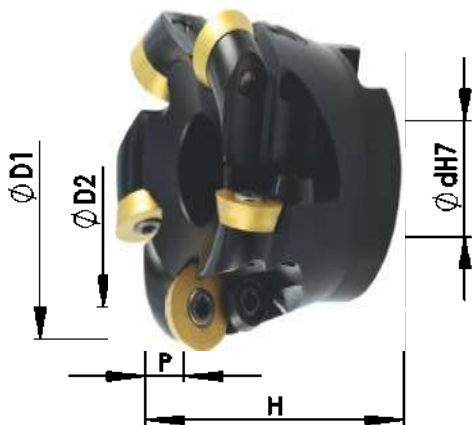

CON REFRIGERAZIONE INTERNA - WITH INTERNAL COOLANT

CODE	D mm	H mm	d mm	P mm	Z No	Insert	Vite Screw	Torx Key
SPRD120401604	40	40	16	6	4	RD..1204	A49M	T15
SPRD120502204	50	50	22	6	4			
SPRD120522205	52	50	22	6	5			
SPRD120632705	63	50	27	6	5			
SPRD120802706	80	50	27	6	6			
SPRD121003207	100	55	32	6	7			

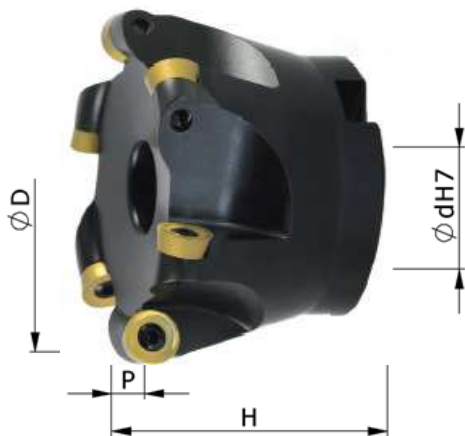

CON REFRIGERAZIONE INTERNA - WITH INTERNAL COOLANT

CODE	D mm	H mm	d mm	P mm	Z No	Insert	Vite Screw	Lock Washer	Lock Washer Screw	Torx Key
SPRD160502204	50	50	22	8	4	RD..1604	A45M	R01	A45M	T20
SPRD160522204	52	50	22	8	4					
SPRD160632705	63	50	27	8	5					
SPRD160662705	66	50	27	8	5					
SPRD160802706	80	50	27	8	6					
SPRD161003207	100	55	32	8	7					
SPRD161254008	125	63	40	8	8					
SPRD161604009	160	55	40	8	9					

FRESE PER SPIANATURE

Shoulder Milling Cutters

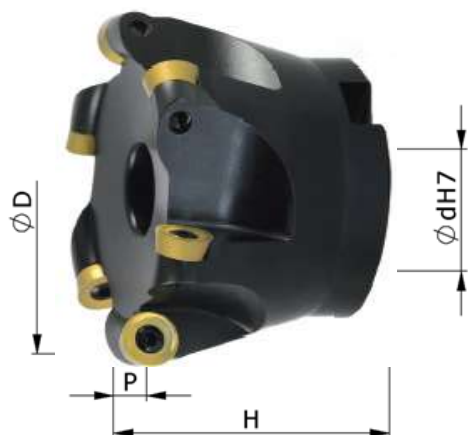

CON REFRIGERAZIONE INTERNA - WITH INTERNAL COOLANT

CODE	D mm	H mm	d mm	P mm	Z No	Insert	Vite Screw	Torx Key
SPRP120401604	40	40	16	6	4	RP..1204	A49M	T15
SPRP120502204	50	40	22	6	4			
SPRP120522204	52	40	22	6	4			
SPRP120632705	63	50	27	6	5			
SPRP120662705	66	50	27	6	5			
SPRP120802706	80	50	27	6	6			
SPRP121003207	100	55	32	6	7			

FRESE PER SPIANATURE 43°

Shoulder Milling Cutters

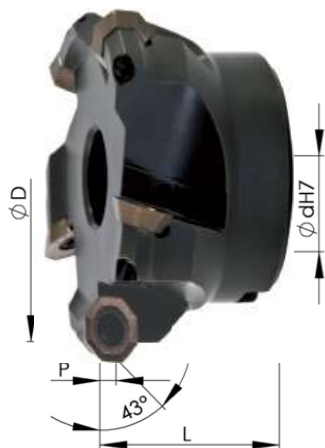

CON REFRIGERAZIONE INTERNA - WITH INTERNAL COOLANT

CODE	D mm	L mm	d mm	P mm	Z No	Insert	Vite Screw	Torx Key
SPOF054303216	32	40	16	3.5	3	OF..05T3	A49M	T15
SPOF054304016	40	40	16	3.5	3			
SPOF054305022	50	40	22	3.5	4			
SPOF054306322	63	40	22	3.5	5			
SPOF054308027	80	50	27	3.5	6			
SPOF054310032	100	50	32	3.5	7			
SPOF054312540	125	63	40	3.5	8			

FRESE PER SPIANATURE 43°

Shoulder Milling Cutters



CON REFRIGERAZIONE INTERNA - WITH INTERNAL COOLANT

CODE	D mm	L mm	d mm	P mm	Z No	Insert	Vite Screw	Torx Key
SPOD064305022	50	40	22	4.5	4	OD..0605	F03	T20
SPOD064306322	63	40	22	4.5	5			
SPOD064308027	80	50	27	4.5	5			
SPOD064310032	100	55	32	4.5	6			
SPOD064312540	125	63	40	4.5	7			
SPOD064316040	160	63	40	4.5	9			

FRESE PER SPIANATURE 45°

Shoulder Milling Cutters

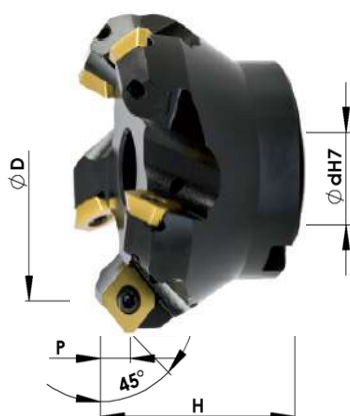

CON REFRIGERAZIONE INTERNA - WITH INTERNAL COOLANT

CODE	D mm	H mm	d mm	P mm	Z No	Insert	Vite Screw	Torx Key
SPSD124505022	50	45	22	6	4	SDKT1204	E02	T20
SPSD124506322	63	45	22	6	5			
SPSD124508027	80	50	27	6	6			
SPSD124510032	100	55	32	6	7			
SPSD124512540	125	63	40	6	8			

FRESE PER SPIANATURE 45°
Shoulder Milling cutters

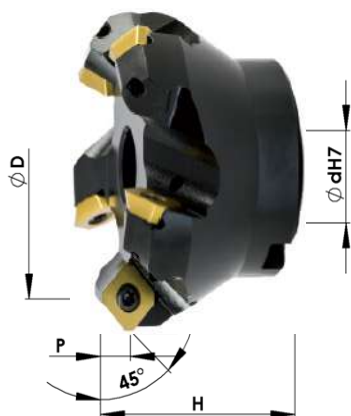

CON REFRIGERAZIONE INTERNA - WITH INTERNAL COOLANT

CODE	D mm	H mm	d mm	P mm	Z No	Insert	Vite Screw	Torx Key
SPSE124504016	40	40	16	6	3	SE..1204	F01	T20
SPSE124505022	50	48	22	6	4		F02	
SPSE124506322	63	48	22	6	5			
SPSE124508032	80	50	27	6	6			
SPSE124510032	100	50	32	6	6			
SPSE124512540	125	63	40	6	7			
SPSE124516040	160	63	40	6	8			

CON REFRIGERAZIONE INTERNA - WITH INTERNAL COOLANT

CODE	D mm	H mm	d mm	P mm	Z No	Insert	Vite Screw	Torx Key
SPSE134505022	50	40	22	6	4	SE..13T3	G01	T15
SPSE134506322	63	40	22	6	5			
SPSE134508027	80	50	27	6	6			
SPSE134510032	100	50	32	6	6			
SPSE134512540	125	63	40	6	7			
SPSE134516040	160	63	40	6	8			

CON REFRIGERAZIONE INTERNA - WITH INTERNAL COOLANT

CODE	D mm	H mm	d mm	P mm	Z No	Insert	Vite Screw	Torx Key
SPSN124505022	50	40	22	7	4	SNMX1205/06	H01	T15
SPSN124506322	63	40	22	7	6			
SPSN124508027	80	50	27	7	7			
SPSN124510032	100	50	32	7	8			
SPSN124512540	125	63	40	7	10			

FRESE PER SPIANATURE 45°

Shoulder Milling Cutters 45°

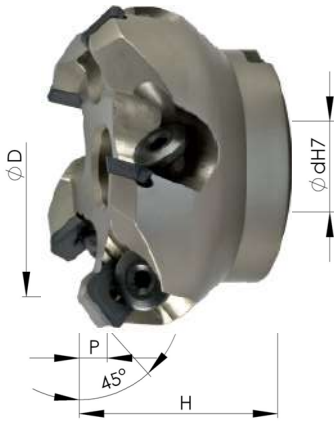

CON REFRIGERAZIONE INTERNA - WITH INTERNAL COOLANT

CODE	D mm	H mm	d mm	P mm	Z No	Insert	Vite Screw	Hexagonal Key
SPSEK124505022	50	48	22	6	4	SEK..1203	L01	4mm
SPSEK124506322	63	48	22	6	5			
SPSEK124508027	80	50	27	6	6			
SPSEK124510032	100	50	32	6	6			
SPSEK124512540	125	63	40	6	7			

FRESE PER SPIANATURE 75°

Shoulder Milling Cutters

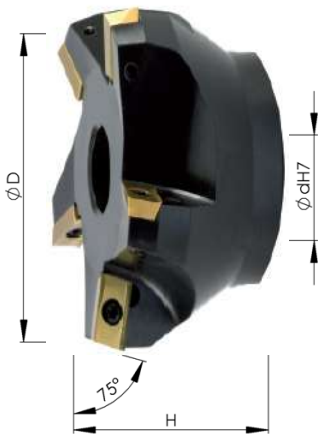

CON REFRIGERAZIONE INTERNA - WITH INTERNAL COOLANT

CODE	D mm	H mm	d mm	Z No	Insert	Vite Screw	Torx Key
SPAD157506322	63	40	22	4	ADKT1505	A49M	T15
SPAD157508027	80	50	27	5			
SPAD157510032	100	50	32	6			

CODE	D mm	H mm	d mm	Z No	Insert	Vite Screw	Torx Key
SPAP167506322	63	40	22	4	AP..1604	A49M	T15
SPAP167508027	80	50	27	5			
SPAP167510032	100	50	32	6			

FRESE A RICCIO

Helical End Mills



CON REFRIGERAZIONE INTERNA - WITH INTERNAL COOLANT

CODE	D mm	L1 mm	L mm	d mm	No Inserts	Z No	Insert	Vite Screw	Torx Key
FAP10R2536100	25	36	100	25	8	2	AP..1003	A26M	T08
FAP10R3245120	32	45	120	32	15	3			

CODE	D mm	L1 mm	L mm	d mm	No Inserts	Z No	Insert	Vite Screw	Torx Key
FAP16R3245125	32	45	125	32	6	2	AP..1604	A49M	T15
FAP16R4070160	40	70	160	40	10	2			

FRESE A RICCIO

Helical End Mills



CON REFRIGERAZIONE INTERNA - WITH INTERNAL COOLANT

CODE	D mm	L1 mm	L mm	d mm	No Inserts	Z No	Insert	Vite Screw	Torx Key
SPAP16R503004	50	30	55	27	8	4	AP..1604	A49M	T15
SPAP16R504403	50	44	70	27	9	3			
SPAP16R633004	63	30	55	27	8	4			
SPAP16R634404	63	44	60	27	12	4			
SPAP16R633005	63	30	55	27	10	5			
SPAP16R803004	80	30	55	32	8	4			
SPAP16R804405	80	44	60	32	15	5			

FRESE A RICCIO

Helical End Mills

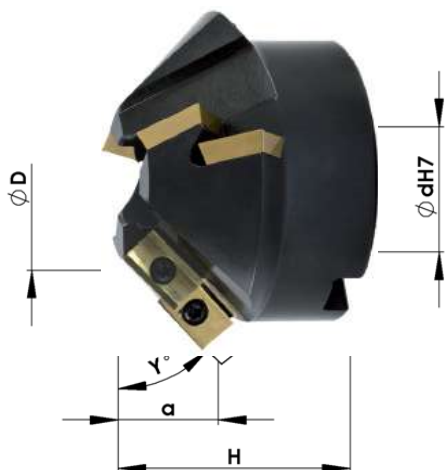

CODE	D mm	D1 mm	a mm	H mm	d mm	γ°	Z No	Insert	Vite Screw	Torx Key
SMAP16359515	35	95.5	7.5	50	27	15	3+3	AP..1604	A49M	T15
SMAP16358830	35	88	15	50	27	30	3+3			
SMAP16357845	35	78	21	50	27	45	3+3			
SMAP16356560	35	65	25.5	50	27	60	3+3			
SMAP16355075	35	50.5	29	60	32	75	3+3			

FRESE PER SMUSSI E SVASATURE

Chamfering Milling cutter

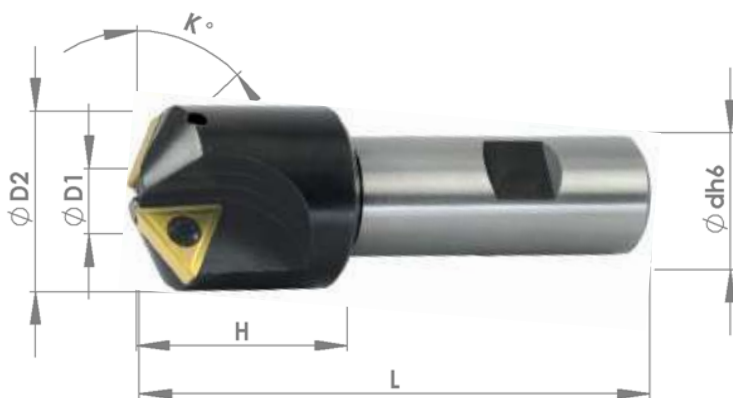

CODE	D1 mm	D2 mm	H mm	L mm	d mm	κ°	Z No	Insert	Vite Screw	Torx Key
SMTC1630603295	6	32	39	95	20	30	2	TC..16T3	A49M	T15
SMTC1645181570	1.8	15.5	20	70	12	45	1	TC..1102	A25M	T07
SMTC1645061990	6	19.5	35	90	20	45	2			
SMTC1645002095	0	20	45	95	20	45	1	TCMX 16T3	A49M	T15
SMTC1645123295	12.5	32.5	39	95	25	45	2	TC..16T3		
SMTC1660541670	5.4	16	20	70	12	60	1	TC..1102	A25M	T07
SMTC1660162690	15.8	26	35	90	20	60	2			
SMTC1660203595	20	35	39	95	25	60	2	TC..16T3	A49M	T15

FRESE PER SMUSSI E SVASATURE

Chamfering Milling cutter

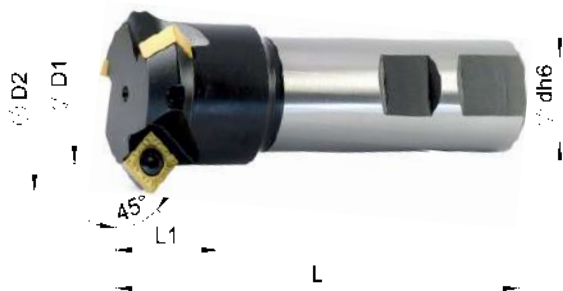

CODE	D1 mm	D2 mm	L1 mm	L mm	d mm	Z No	Insert	Vite Screw	Torx Key
SMSC09451223100	12	23.7	25	100	20	1	SC..09T3	A49M	T15
SMSC09451628100	16	28.8	35	100	20	2			
SMSC09453042100	30	42.3	35	100	25	3			
SMSC09451223200	12	23.7	25	200	20	1			
SMSC09451628200	16	28.8	42	200	20	2			
SMSC09453042200	30	42.3	40	200	25	3			

FRESE PER LAMATURE

Spot Facing Milling Cutters



CON REFRIGERAZIONE INTERNA - WITH INTERNAL COOLANT

CODE	D mm	a mm	L1 mm	L mm	d mm	Z No	Insert	Vite Screw	Torx Key
LMCC06150530085	15	5	30	85	12	1	CC..0602	A25M	T07
LMCC06160530092	16	5	30	92	12	2			
LMCC06170632094	17	6	32	94	16	2			
LMCC06170640096	17.5	6.5	40	96	16	2			
LMCC06180741097	18	7	41	97	16	2			
LMCC06190841100	19	8	41	100	16	2			
LMCC06200941102	20	9	41	102	16	2			
LMCC06211041105	21	10	41	105	16	2			
LMCC06221141110	22	11	41	110	16	2			
LMCC06231241112	23	12	41	112	16	2			
LMCC06241341115	24	13	41	115	16	2			
LMCC06250840120	25	8	40	120	16	2	CC..09T3	A48M	T15
LMCC06260955125	26	9	55	125	20	2			
LMCC06271055128	27	10	55	128	20	2			
LMCC06281155130	28	11	55	130	20	2			
LMCC06291255132	29	12	55	132	20	2			
LMCC06301355134	30	13	55	134	20	2			
LMCC06311455136	31	14	55	136	20	2			
LMCC06321555138	32	15	55	138	20	2			
LMCC06331655140	33	16	55	140	20	2			
LMCC06341660140	34	16	60	140	25	2			
LMCC06351760140	35	17	60	140	25	2			
LMCC06382060140	38	20	60	140	25	2	CC..09T3	A49M	
LMCC06422460140	42	24	60	140	25	2			

FRESE PER LAMATURE
Spot Facing Milling Cutters



CON REFRIGERAZIONE INTERNA - WITH INTERNAL COOLANT

CODE	D mm	L1 mm	L mm	d mm	Z No	Insert	Vite Screw	Torx Key
ALCC061023090	9.8	23	90	8	1	CC..0602	A25M	T07
ALCC061124105	10.8	24	105	10	1			
ALCC061225105	11.8	25	105	10	1			
ALCC061325105	12.8	26	105	10	1			
ALCC061427110	13.8	27	110	12	1			
ALCC061528120	14.8	28	120	12	1			
ALCC061629125	15.8	29	125	12	1			
ALCC061730140	16.8	30	140	16	1			
ALCC061831140	17.8	31	140	16	1			
ALCC061931150	18.8	32	150	16	1			
ALCC062033150	19.8	33	150	16	1			
ALCC062134150	20.8	34	160	20	1	CC..09T3	A48M	T15
ALCC062235160	21.8	35	160	20	1			
ALCC062336165	22.8	36	165	20	1			
ALCC062437170	23.8	37	170	20	1			
ALCC062538180	24.8	38	180	20	1			
ALCC062639185	25.8	39	185	20	1			
ALCC062740190	26.8	40	190	20	1			
ALCC062840190	27.8	41	190	20	1			
ALCC062943200	28.8	42	200	20	1			
ALCC063043200	29.8	43	200	25	1			
ALCC063144200	30.8	44	200	25	1			
ALCC063245200	31.8	45	200	25	1			

LAME PER TAGLIO E GOLA

Blades for Parting-Off

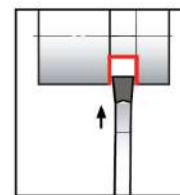
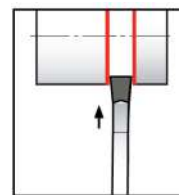
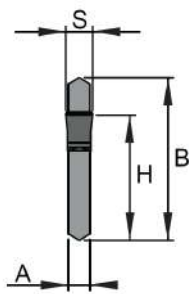
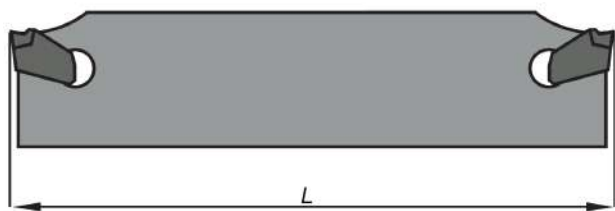

CODE	B mm	S mm	H mm	A mm	L mm	Insert	Chiave Key
LAMVRST19-1	19	2	16	1.6	85	VRST-101	5mm
LAMVRST26-1	26	2	21.4	1.6	110		
LAMVRST26-2	26	3	21.4	2.4	110		
LAMVRST26-3	26	4	21.4	3.2	110		
LAMVRST26-4	26	5	21.4	4	110		
LAMVRST26-5	26	6	21.4	5.2	110	VRST-105	
LAMVRST32-1	32	2	26	1.6	150	VRST-101	
LAMVRST32-2	32	3	26	2.4	150	VRST-102	
LAMVRST32-3	32	4	26	3.2	150	VRST-103	
LAMVRST32-4	32	5	26	4	150	VRST-104	
LAMVRST32-5	32	6	26	5.2	150	VRST-105	

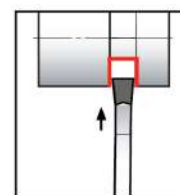
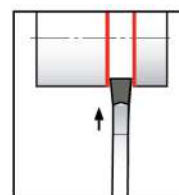
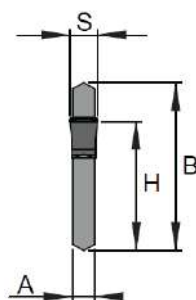

CODE	B mm	S mm	H mm	A mm	L mm	Insert	Chiave Key
LAMVRSU32-1	32	3	25	2.4	150	VRSU-101	5mm
LAMVRSU32-2	32	4	25	3.2	150	VRSU-102	
LAMVRSU32-3	32	5	25	4	150	VRSU-103	



Nuova C.U.M.E.T. Srl - Via Torino, 502
10032 Brandizzo (TO) ITALY
Tel: +39 011 917 95 14/15
Telefax: +39 011 917 95 55/02
www.nuovacumet.it • info@nuovacumet.it

B.A. Machinery
Beijing
Tel: (86)-10-63777466/76
Telefax: (86)-10-63777486
www.nuovacumet.cn • info@nuovacumet.cn

CUMET Tools s.r.o.
Vilová 298/1746010 - Liberec 10
Czech Republic
GSM +420-602 232 383
www.cumet.cz • zuda@cumet.cz