

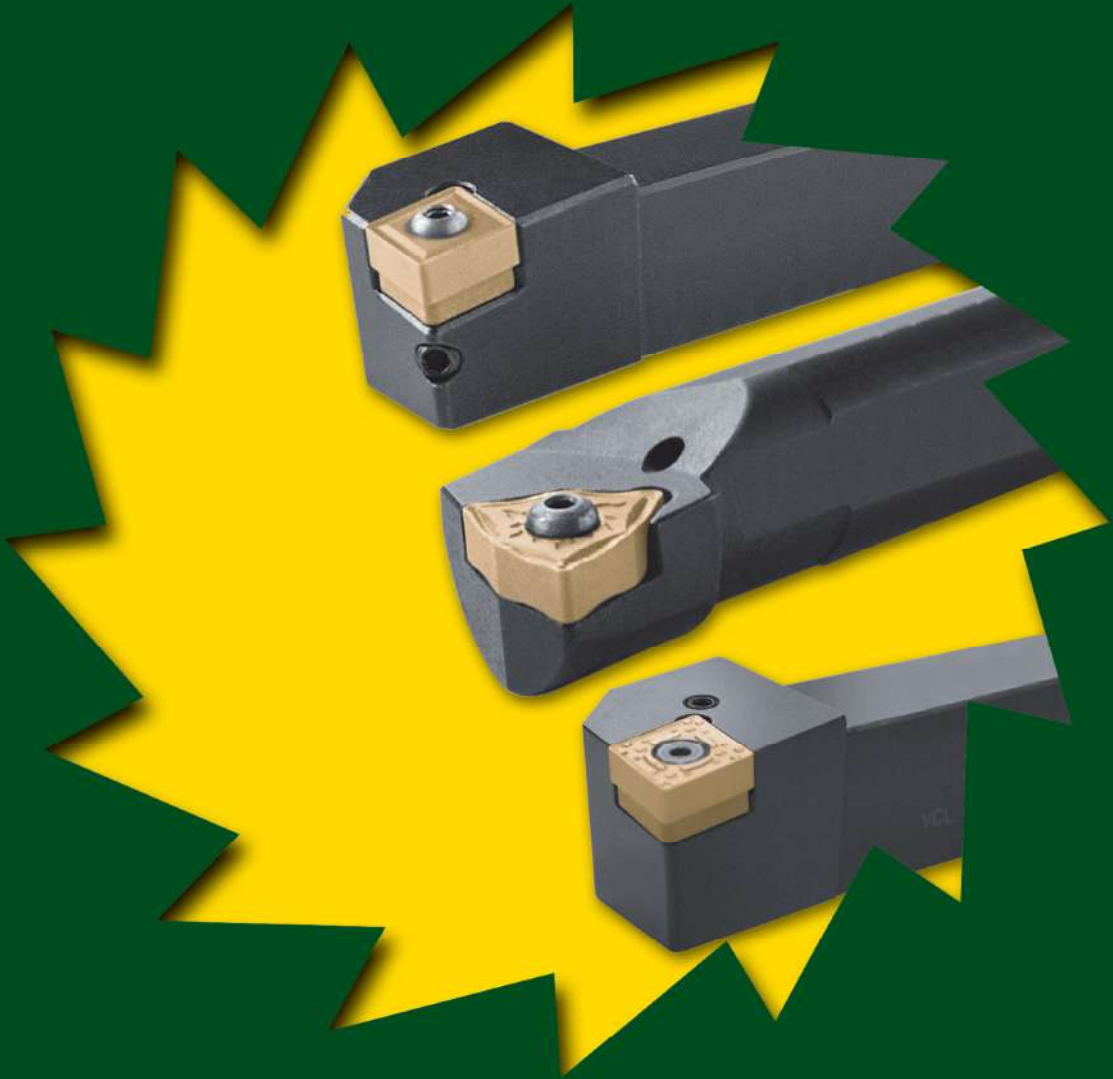

Nuova C.U.M.E.T. Patent Tool Holder



Precision in *movement!*



PATENT TOOL HOLDER SYSTEM

V-BLOCK S Y S T E M

THE NEW SISTEM OF
PATENTED CLAMPING.
SIMPLE, EFFICIENT, ECONOMIC

- MAXIMUM STABILITY AND SAFETY
IN TURNING GUARANTEED
 - LONGER TOOL LIFE COMPARED
WITH TRADITIONAL CLAMPING
SYSTEMS
 - ALLOWS A REDUCED NUMBER OF SPARE
PARTS
- SEMPPLICITY OF USE THANKS TO ONE KEY

VV BLOCK



VL BLOCK



VLV BLOCK

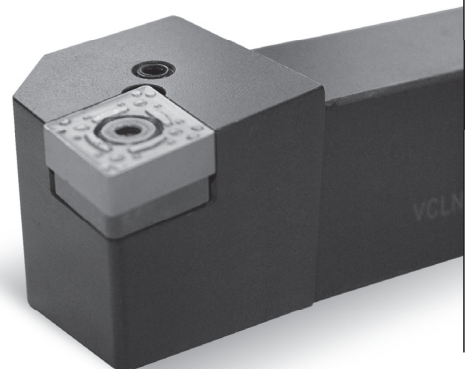

EXTERNAL TURNING V-BLOCK SYSTEM

Page

TOOLS FOR NEGATIVE INSERTS

INSTRUCTIONS	4-5
Insert CN	6-7-8
Insert DN	9
Insert SN	10-11-12
Insert TN	12-13-14
Insert VN	14-15
Insert WN	15
TOOLS FOR POSITIVE INSERT WITH HOLE	
Insert DC	16
Insert VB	16-17
Insert VC	17-18

EXTERNAL TURNING CLAMPING SYSTEM

S	25	T	P	C	L	N	R	12
10	11	8	1	2	3	4	5	9

Clamping System

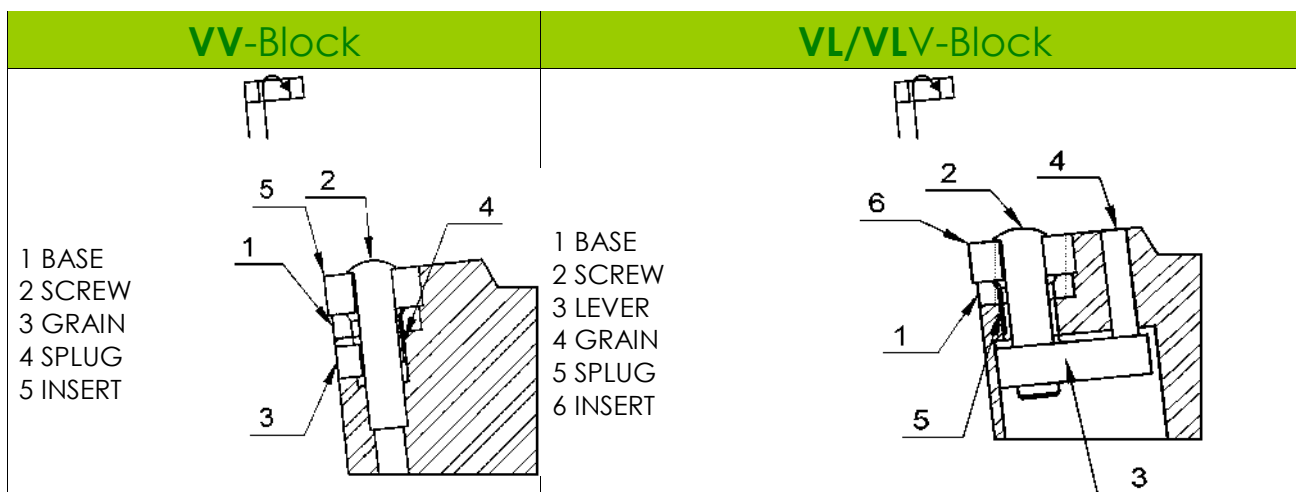

CUTTING DATA VV-BLOCK SYSTEM EXAMPLES

REGULAR TURNING

Insert: **CNMG120408**
 Material: Hardened steel 42CrMo4
 VT=120M
 Rpm= 770'
 AZ= 0.8mm
 Ap= 4mm Radius
 Dry Cutting.
 CUTTING STRESS HAS STOPPED
 ROTATING SPINDLE. INSERT THERE
 HAS N'T BROKEN!

INTERRUPTED CUT

Insert: **DNMG15 R=1.2**
 Material: Hardened steel 42NiCrMo4
 Diameter: 90mm (Finished = 63mm)
 VT=140M
 AZ= 0.8mm
 Ap= 4mm Radius
 With Coolant.
 TOTAL WORKED PCS. 84
 COMPETITOR= 18-20 PCS. MAX

V-BLOCK SYSTEM

THE NEW SYSTEM OF
PATENTED CLAMPING,
SIMPLE, EFFICIENT AND ECONOMIC

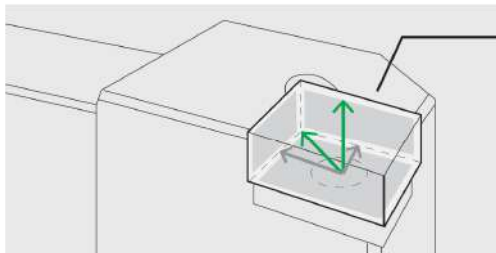

LOCKED FORCE OPTIMAL POSITION

REDUCED
NUMBER OF
SPARE PARTS

BEST CHIP
EVACUATION

LESS
VIBRATIONS

MAJOR
INSERT
TOOL LIFE

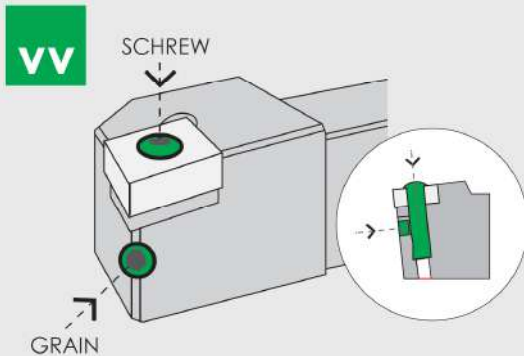

• **SAFE**

- Stability and security in Turning.
- Excellent chip evacuation (there isn't the encumbrance of the bracket).

• **EFFICIENT**

- Major insert Tool Life compared to the traditional lever Systems.
- Reduced numbers of spare parts.

• **SIMPLE**

- Easy of use (One key only)

• **FOR POSITIVE & NEGATIVE INSERTS WITH HOLE ***

• **INTERNAL AND EXTERNAL TURNING**

VL FOR INSERTS OF
SMALL AND MEDIUM DIMENSIONS

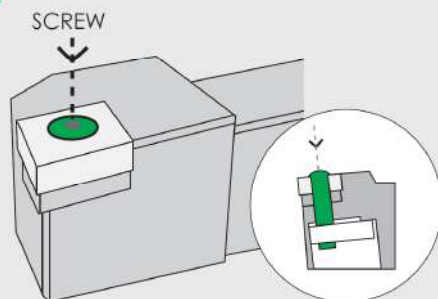

The locking system **VL - BLOCK SYSTEM** offers **improved ease** of use compared to the VV - BLOCK SYSTEM . In addition to ensuring excellent performance in interrupted cuts and hostile environments, ensures maximum stability and safety even **in cases of severe removal of material.**

• **SAFE**

- Stability and security in Turning.
- Excellent chip evacuation (there isn't the encumbrance of the bracket).

• **EFFICIENT**

- Major insert Tool Life compared to the traditional lever Systems.

- Reduced numbers of spare parts.

• **SIMPLE**

- Easy of use (One key only)

• **FOR POSITIVE & NEGATIVE INSERTS WITH HOLE ***

• **IDEAL FOR HEAVY APPLICATIONS**

• **INTERNAL AND EXTERNAL TURNING**

VLV FOR INSERTS OF
BIG DIMENSIONS (from 19mm)

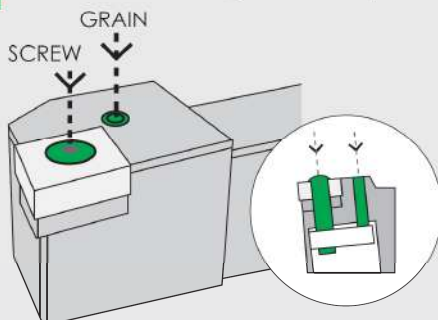

The **V-BLOCK** are flexible system that allow, on the same tool holder, the use of the following inserts:

* **SOLID CARBIDE / CBN / CERAMIC WITH HOLES / POLYCRISTALLYNE**

VV

ASSEMBLY

- LOOSEN GRAIN 1
- REMOVE SCREW 2
- MOUNT INSERT 3
- INSERT SCREW 2
(don't use excessive force)
- TIGHTEN GRAIN 1

DISASSEMBLY

- LOOSEN GRAIN 1
- REMOVE SCREW 2
- REMOVE INSERT 3

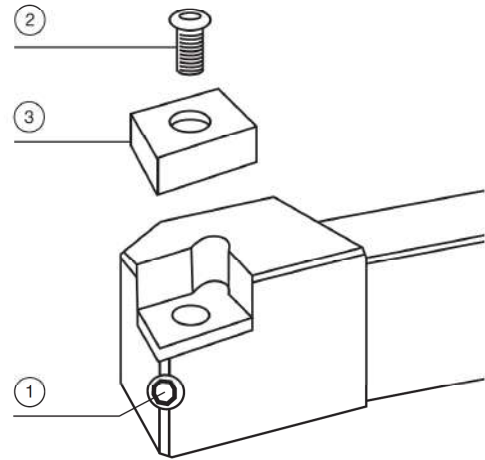

VL

ASSEMBLY

- REMOVE SCREW 1
- MOUNT INSERT 2
- TIGHTEN SCREW 1

DISASSEMBLY

- REMOVE SCREW 1
- REMOVE INSERT 2

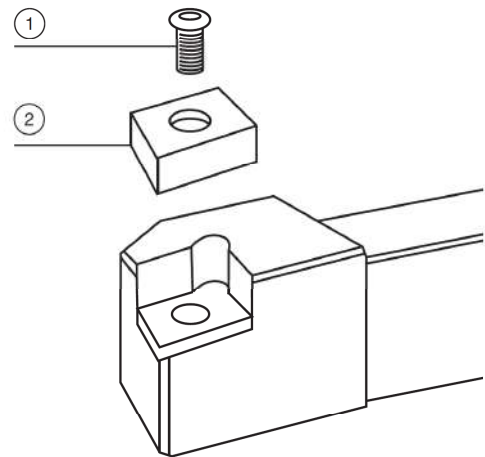

VLV

ASSEMBLY

- LOOSEN GRAIN 1
- REMOVE SCREW 2
- MOUNT INSERT 3
- INSERT SCREW 2
- TIGHTEN GRAIN 1

DISASSEMBLY

- LOOSEN GRAIN 1
- REMOVE SCREW 2
- REMOVE INSERT 3

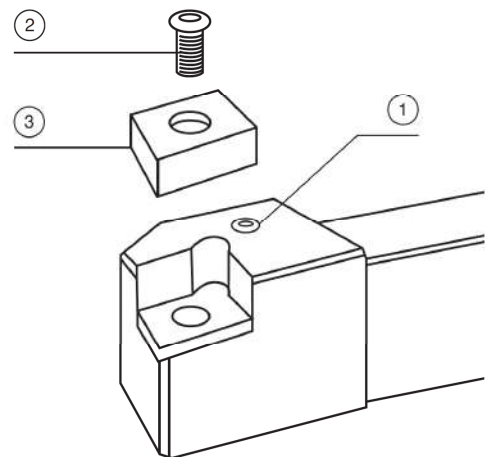

NEGATIVE INSERT	INSERTS CN..1204 CN..1606 CN..1906 CN..2509 CN..3109	EXTERNAL TURNING
CN		95°

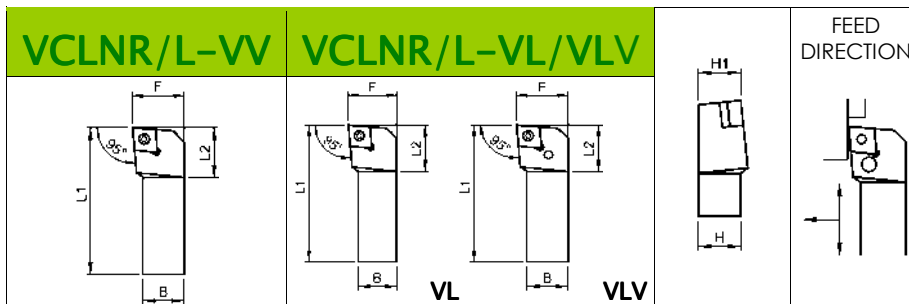

THE DRAWINGS REPRESENT RIGHT TOOLS • ANGLE OF INCLINATION = -6° • SUPERIOR RELIEF ANGLE = -6°

V-BLOCK SYSTEM • VCLNR/L-VV is Patent Tool Holder

	CODE	H	H1	B	L1	L2	F			#				
12	VCLNR/L 2020 K12-VV	20	20	20	125	30	25	A1	VV5	VV5P	VG5	D1	2.5	
	VCLNR/L 2525 M12-VV	25	25	25	150	32	32							
	VCLNR/L 3225 P12-VV	32	32	25	170	35	32							
	VCLNR/L 3232 P12-VV	32	32	32	170	35	40							
16	VCLNR/L 2525 M16-VV	25	25	25	150	32	32	Y2	VV6	VV6P	VG6	D5		
	VCLNR/L 3225 P16-VV	32	32	25	170	35	32							
	VCLNR/L 3232 P16-VV	32	32	32	170	35	40							
	VCLNR/L 4040 S16-VV	40	40	40	250	40	50							
19	VCLNR/L 3225 P19-VV	32	32	25	170	42	32	A2	VV8	-	VG8L	D2	3	
	VCLNR/L 3232 P19-VV	32	32	32	170	42	40							
	VCLNR/L 4040 S19-VV	40	40	40	250	50	50							
25	VCLNR/L 4040 S25-VV	40	40	40	250	50	50	Y3	VV9	-	VG9	D4	4	
	VCLNR/L 5050 T25-VV	50	50	50	300	50	60							

Specific screw for insert CBN, PCD o CERAMICS WITH HOLE

V-BLOCK SYSTEM • VCLNR/L-VL/VLV are Patent Tool Holder

	CODE	H	H1	B	L1	L2	F			#				
12	VCLNR/L 2020 K12-VL	20	20	20	125	30	25	A1	VL5	VL5P	LE5	-	D1	VS5
	VCLNR/L 2525 M12-VL	25	25	25	150	32	32							
	VCLNR/L 3225 P12-VL	32	32	25	170	35	32							
	VCLNR/L 3232 P12-VL	32	32	32	170	35	40							
16	VCLNR/L 2525 M16-VL	25	25	25	150	32	32	Y2	VL6	VL6P	LE6	-	D5	VS6
	VCLNR/L 3225 P16-VL	32	32	25	170	35	32							
	VCLNR/L 3232 P16-VL	32	32	32	170	35	40							
19	VCLNR/L 3232 P19-VLV	32	32	32	170	42	40	A2	VL8	-	LE8	VLG8	D2	VS8
	VCLNR/L 4040 S19-VLV	40	40	40	250	50	50							
25	VCLNR/L 4040 S25-VLV	40	40	40	250	50	50	Y3	VL9	-	LE9	VLG9	D4	SE9
	VCLNR/L 5050 T25-VLV	50	50	50	300	50	60							
31	VCLNR/L 4040 S31-VLV	40	40	40	250	60	50	A15	VL10	-	LE10	VLG10	D4	SE10
	VCLNR/L 5050 T31-VLV	50	50	50	300	60	60							

Specific screw for insert CBN, PCD o CERAMICS WITH HOLE

NEGATIVE INSERT CN	INSERTS CN..1204 CN..1606 CN..1906 CN..2509 CN..3109	EXTERNAL TURNING 75°
--	---	--

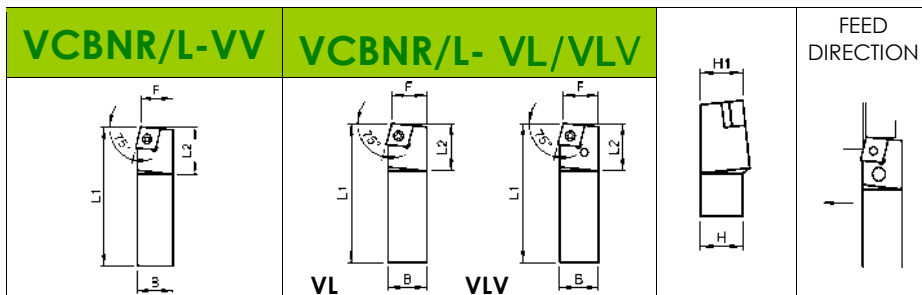

THE DRAWINGS RAPPRESENT RIGHT TOOLS • ANGLE OF INCLINATION = -6° • SUPERIOR RELIEF ANGLE = -6°

V-BLOCK SYSTEM • VCBNR/L-VV is Patent Tool Holder

	CODE	H	H1	B	L1	L2	F									
12	VCBNR/L 2020 K12-VV	20	20	20	125	30	17	A1	VV5	VV5P	VG5	D1	2.5			
	VCBNR/L 2525 M12-VV	25	25	25	150	32	22									
	VCBNR/L 3225 P12-VV	32	32	25	170	35	22									
16	VCBNR/L 2525 M16-VV	25	25	25	150	32	22	Y2	VV6	VV6P	VG6	D5			2.5	
	VCBNR/L 3225 P16-VV	32	32	25	170	35	22									
	VCBNR/L 3232 P16-VV	32	32	32	170	35	27									
19	VCBNR/L 3232 P19-VV	32	32	32	170	42	27	A2	VV8		VG8L	D2	3			
	VCBNR/L 4040 S19-VV	40	40	40	250	50	35									
25	VCBNR/L 4040 S25-VV	40	40	40	250	50	35	Y3	VV9		VG9	D4				
	VCBNR/L 5050 T25-VV	50	50	50	300	50	43									

Specific screw for insert CBN, PCD o CERAMICS WITH HOLE

V-BLOCK SYSTEM • VCBNR/L-VL/VLV are Patent Tool Holder

	CODE	H	H1	B	L1	L2	F										
12	VCBNR/L 2020 K12-VL	20	20	20	125	30	17	A1	VL5	VL5P	LE5	-	D1	VS5	2.5		
	VCBNR/L 2525 M12-VL	25	25	25	150	32	22										
	VCBNR/L 3225 P12-VL	32	32	25	170	35	22										
16	VCBNR/L 2525 M16-VL	25	25	25	150	32	22	Y2	VL6	VL6P	LE6	-	D5	VS6		2.5	
	VCBNR/L 3225 P16-VL	32	32	25	170	35	22										
	VCBNR/L 3232 P16-VL	32	32	32	170	35	27										
19	VCBNR/L 3232 P19-VLV	32	32	32	170	42	27	A2	VL8		LE8	VLG8	D2	VS8	3		
	VCBNR/L 4040 S19-VLV	40	40	40	250	50	35										
25	VCBNR/L 4040 S25-VLV	40	40	40	250	50	35	Y3	VL9		LE9	VLG9	D4	SE9			3
	VCBNR/L 5050 T25-VLV	50	50	50	300	50	43										
31	VCBNR/L 4040 S31-VLV	40	40	40	250	60	44	A15	VL10		LE10	VLG10	D4	SE10		3	
	VCBNR/L 5050 T31-VLV	50	50	50	300	60	44										

Specific screw for insert CBN, PCD o CERAMICS WITH HOLE

NEGATIVE INSERT <h1 style="margin: 0;">CN</h1>	INSERTS CN..1204 CN..1606 CN..1906	EXTERNAL TURNING <h1 style="margin: 0;">15°</h1>
--	---	--

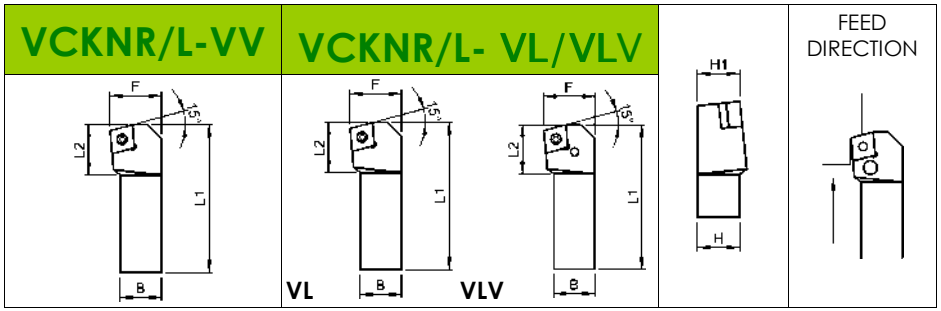

THE DRAWINGS RAPPRESENT RIGHT TOOLS • ANGLE OF INCLINATION = -6° • SUPERIOR RELIEF ANGLE = -6°

V-BLOCK SYSTEM • VCKNR/L-VV is Patent Tool Holder

	CODE	H	H1	B	L1	L2	F						
12	VCKNR/L 2020 K12-VV	20	20	20	125	30	25	A1	VV5	VV5P	VG5	D1	2.5
	VCKNR/L 2525 M12-VV	25	25	25	150	32	32						
	VCKNR/L 3225 P12-VV	32	32	25	170	35	32						
16	VCKNR/L 2525 M16-VV	25	25	25	150	32	32	Y2	VV6	VV6P	VG6	D5	2.5
	VCKNR/L 3225 P16-VV	32	32	25	170	35	32						
	VCKNR/L 3232 P16-VV	32	32	32	170	35	40						
19	VCKNR/L 3232 P19-VV	32	32	32	170	42	40	A2	VV8		VG8L	D2	3
	VCKNR/L 4040 S19-VV	40	40	40	250	50	50						

Specific screw for insert CBN, PCD o CERAMICS WITH HOLE

V-BLOCK SYSTEM • VCKNR/L-VL/VLV are Patent Tool Holder

	CODE	H	H1	B	L1	L2	F							
12	VCKNR/L 2020 K12-VL	20	20	20	125	30	25	A1	VL5	VL5P	LE5	-	D1	VS5
	VCKNR/L 2525 M12-VL	25	25	25	150	32	32							
	VCKNR/L 3225 P12-VL	32	32	25	170	35	32							
16	VCKNR/L 2525 M16-VL	25	25	25	150	32	32	Y2	VL6	VL6P	LE6	-	D5	VS6
	VCKNR/L 3225 P16-VL	32	32	25	170	35	32							
	VCKNR/L 3232 P16-VL	32	32	32	170	35	40							
19	VCKNR/L 3232 P19-VLV	32	32	32	170	42	40	A2	VL8		LE8	VLG8	D2	VS8
	VCKNR/L 4040 S19-VLV	40	40	40	250	50	50							

Specific screw for insert CBN, PCD o CERAMICS WITH HOLE

NEGATIVE INSERT **INSERTS DN..1104 DN..1506** **EXTERNAL TURNING**
DN **93°**

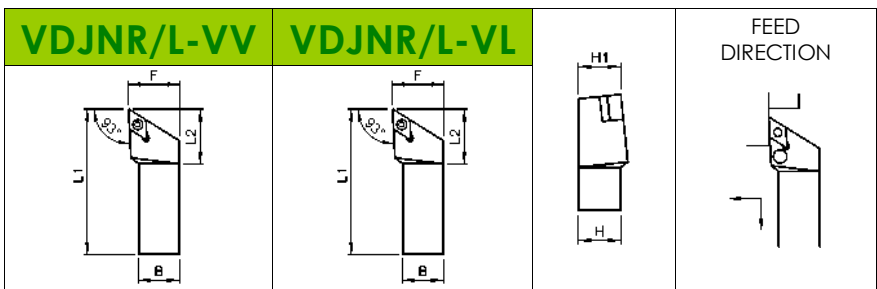

THE DRAWINGS RAPPRESENT RIGHT TOOLS • ANGLE OF INCLINATION = -6° • SUPERIOR RELIEF ANGLE = -6°

V-BLOCK SYSTEM • VDJNR/L-VV is Patent Tool Holder

	CODE	H	H1	B	L1	L2	F			#			
11	VDJNR/L 2020 K11-VV	20	20	20	125	25	25	A17	VV4	VV4P	VG4	D3	2
	VDJNR/L 2525 M11-VV	25	25	25	150	32	32						
15	VDJNR/L 2020 K15-VV	20	20	20	125	35	25	A3	VV5	VV5P	VG5L	D1	2.5
	VDJNR/L 2525 M15-VV	25	25	25	150	37	32						
	VDJNR/L 3225 P15-VV	32	32	25	170	35	32						
	VDJNR/L 3232 P15-VV	32	32	32	170	35	40						
	VDJNR/L 4040 S15-VV	40	40	40	250	40	50						
VDJNR/L 5050 T15-VV	50	50	50	300	50	60							

V-BLOCK SYSTEM • VDJNR/L-VL is Patent Tool Holder

	CODE	H	H1	B	L1	L2	F			#				
15	VDJNR/L 2020 K15-VL	20	20	20	125	35	25	A3	VL5L	VL5LP	LE5	D1	VS5	2.5
	VDJNR/L 2525 M15-VL	25	25	25	150	37	32							
	VDJNR/L 3225 P15-VL	32	32	25	170	35	32							
	VDJNR/L 3232 P15-VL	32	32	32	170	35	32							

Specific screw for insert CBN, PCD o CERAMICS WITH HOLE

NEGATIVE INSERT **INSERTS DN..1506** **EXTERNAL TURNING**
DN **62.5°**

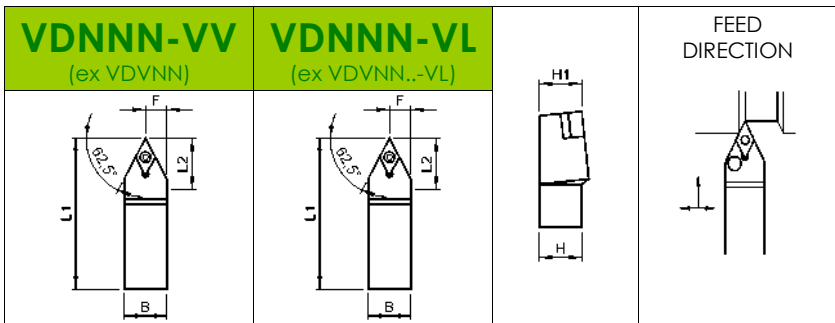

THE DRAWINGS RAPPRESENT RIGHT TOOLS • ANGLE OF INCLINATION = -9° • SUPERIOR RELIEF ANGLE = -5°

V-BLOCK SYSTEM • VDNNN/L-VV is Patent Tool Holder

	CODE	H	H1	B	L1	L2	F			#			
15	VDNNN 2020 K15-VV	20	20	20	125	40	10	A3	VV5	VV5P	VG5L	D1	2.5
	VDNNN 2525 M15-VV	25	25	25	150	37	12.5						
	VDNNN 3225 P15-VV	32	32	25	170	42	12.5						
	VDNNN 3232 P15-VV	32	32	32	170	42	16						
	VDNNN 4040 S15-VV	40	40	40	250	40	20						
	VDNNN 5050 T15-VV	50	50	50	300	50	25						

	CODE	H	H1	B	L1	L2	F			#				
15	VDNNN 2020 K15-VL	20	20	20	125	40	10	A3	VL5L	VL5LP	LE5	D1	VS5	2.5
	VDNNN 2525 M15-VL	25	25	25	150	37	12.5							
	VDNNN 3225 P15-VL	32	32	25	170	42	12.5							
	VDNNN 3232 P15-VL	32	32	32	170	42	16							

Specific screw for insert CBN, PCD o CERAMICS WITH HOLE

NEGATIVE INSERT SN	INSERTS	SN..1204 SN..1506 SN..1906 SN..2507 SN..2509 SN..3109	EXTERNAL TURNING 75°
	(VLV)		

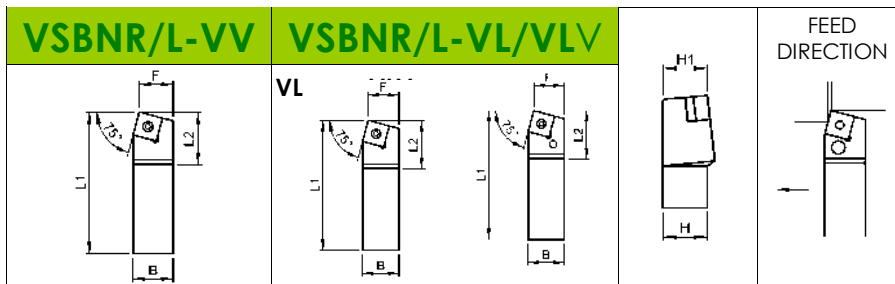

THE DRAWINGS RAPPRESENT RIGHT TOOLS • ANGLE OF INCLINATION = -6° • SUPERIOR RELIEF ANGLE = -6°

V-BLOCK SYSTEM • VSBNR/L-VV is Patent Tool Holder

CODE	H	H1	B	L1	L2	F			#				
12	VSBNR/L 2020 K12-VV	20	20	20	125	30	17	A4	VV5	VV5P	VG5	D1	2.5
	VSBNR/L 2525 M12-VV	25	25	25	150	32	22						
	VSBNR/L 3225 P12-VV	32	32	25	170	35	22						
15	VSBNR/L 2525 M15-VV	25	25	25	150	32	22	Y1	VV6	VV6P	VG6	D5	
	VSBNR/L 3225 P15-VV	32	32	25	170	35	22						
	VSBNR/L 3232 P15-VV	32	32	32	170	35	27						
19	VSBNR/L 3232 P19-VV	32	32	32	170	42	27	A5	VV8	VG8L	D2	3	
	VSBNR/L 4040 S19-VV	40	40	40	250	50	35						
25	VSBNR/L 4040 S25-VV	40	40	40	250	50	35	Y8	VV9	VG9	D4	4	
	VSBNR/L 5050 T25-VV	50	50	50	300	50	43						

Specific screw for insert CBN, PCD o CERAMICS WITH HOLE

V BLOCK SYSTEM • VSBNR/L-VL/VLV are Patent Tool Holder

CODE	H	H1	B	L1	L2	F			#					
12	VSBNR/L 2020 K12-VL	20	20	20	125	30	17	A4	VL5	VL5P	LE5	-	D1	VS5
	VSBNR/L 2525 M12-VL	25	25	25	150	32	22							
	VSBNR/L 3225 P12-VL	32	32	25	170	35	22							
15	VSBNR/L 2525 M15-VL	25	25	25	150	32	22	Y1	VL6	VL6P	LE6	-	D5	VS6
	VSBNR/L 3225 P15-VL	32	32	25	170	35	22							
	VSBNR/L 3232 P15-VL	32	32	32	170	35	27							
19	VSBNR/L 3232 P19-VLV	32	32	32	170	42	27	A5	VL8	LE8	VLG8	D2	VS8	
	VSBNR/L 4040 S19-VLV	40	40	40	250	50	35							
25	VSBNR/L 4040 S25-VLV	40	40	40	250	50	35	Y8	VL9	LE9	VLG9	D4	SE9	
	VSBNR/L 5050 T25-VLV	50	50	50	300	50	43							
31	VSBNR/L 4040 S31-VLV	40	40	40	250	60	44	A14	VL10	LE10	VLG10	D4	SE10	
	VSBNR/L 5050 T31-VLV	50	50	50	300	60	44							

Specific screw for insert CBN, PCD o CERAMICS WITH HOLE

Insert from 25mm: Tool for insert SN..2509 – For using the insert SN..2507 order separately the support Y8H

NEGATIVE INSERT SN	INSERTS SN..1204 SN..1506 SN..1906 SN..2507 SN..2509	EXTERNAL TURNING 45° (VLV)
--	---	---

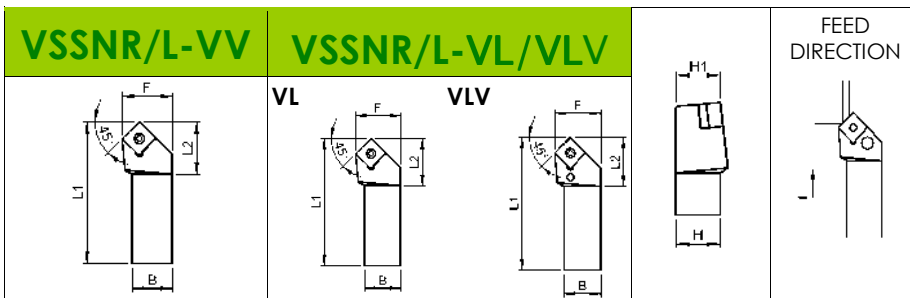

THE DRAWINGS RAPPRESENT RIGHT TOOLS • ANGLE OF INCLINATION = -0° • SUPERIOR RELIEF ANGLE = -8°

V-BLOCK SYSTEM • VSSNR/L-VV is a Patent Tool Holder

CODE	H	H1	B	L1	L2	F	Icon 1	Icon 2	Icon 3 #	Icon 4	Icon 5	Icon 6
12	VSSNR/L 2020 K12-VV	20	20	20	125	30	25	A4	VV5	VV5P	VG5	D1
	VSSNR/L 2525 M12-VV	25	25	25	150	37	32					
	VSSNR/L 3225 P12-VV	32	32	25	170	35	32					
15	VSSNR/L 2525 M15-VV	25	25	25	150	37	32	Y1	VV6	VV6P	VG6	D5
	VSSNR/L 3225 P15-VV	32	32	25	170	35	32					
	VSSNR/L 3232 P15-VV	32	32	32	170	35	40					
19	VSSNR/L 3232 P19-VV	32	32	32	170	42	40	A5	VV8	-	VG8L	D2
	VSSNR/L 4040 S19-VV	40	40	40	250	50	50					
25	VSSNR/L 4040 S25-VV	40	40	40	250	50	50	Y8	VV9	-	VG9	D4
	VSSNR/L 5050 T25-VV	50	50	50	300	50	60					

Specific screw for insert CBN, PCD o CERAMICS WITH HOLE

V-BLOCK SYSTEM • VSSNR/L-VL/VLV are Patent Tool Holder

CODE	H	H1	B	L1	L2	F	Icon 1	Icon 2	Icon 3 #	Icon 4	Icon 5	Icon 6	Icon 7
12	VSSNR/L 2020 K12-VL	20	20	20	125	30	25	A4	VL5	VL5P	LE5	-	D1
	VSSNR/L 2525 M12-VL	25	25	25	150	37	32						
	VSSNR/L 3225 P12-VL	32	32	25	170	35	32						
15	VSSNR/L 2525 M15-VL	25	25	25	150	37	32	Y1	VL6	VL6P	LE6	-	D5
	VSSNR/L 3225 P15-VL	32	32	25	170	35	32						
	VSSNR/L 3232 P15-VL	32	32	32	170	35	40						
19	VSSNR/L 3232 P19-VLV	32	32	32	170	42	40	A5	VL8	-	LE8	VLG8	D2
	VSSNR/L 4040 S19-VLV	40	40	40	250	50	50						
25	VSSNR/L 4040 S25-VLV	40	40	40	250	50	50	Y8	VL9	-	LE9	VLG9	D4
	VSSNR/L 5050 T25-VLV	50	50	50	300	50	60						

Specific screw for insert CBN, PCD o CERAMICS WITH HOLE

Insert from 25mm: Tool for insert SN..2509 – For using the insert SN..2507 order separately the support Y8H

NEGATIVE INSERTS SN	INSERTS SN..1204 SN..1506 SN..1906 SN..2507 SN..2509	EXTERNAL TURNING 45° (VLV)
--------------------------------------	---	--

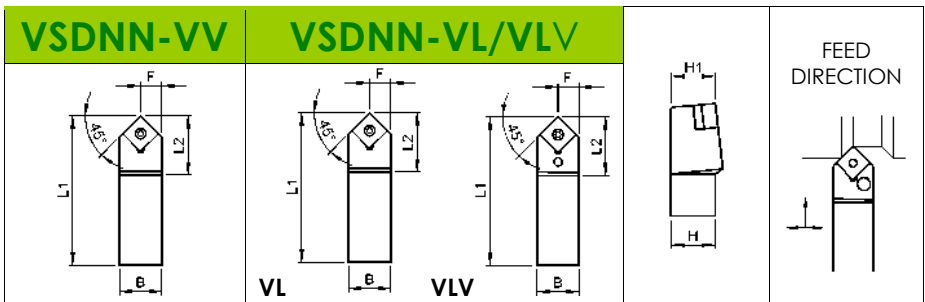

THE DRAWINGS RAPPRESENT RIGHT TOOLS • ANGLE OF INCLINATION = -6° • SUPERIOR RELIEF ANGLE = -6°

V-BLOCK SYSTEM • VSDNNR/L-VV is Patent Tool Holder

CODE	H	H1	B	L1	L2	F		#				
12 VSDNN 2020 K12-VV	20	20	20	125	30	10.3	A4	VV5	VV5P	VG5C	D1	2.5
VSDNN 2525 M12-VV	25	25	25	150	35	12.8						
VSDNN 3225 P12-VV	32	32	25	170	35	12.8						
15 VSDNN 2525 M15-VV	25	25	25	150	32	12.8	Y1	VV6	VV6P	VG6	D5	
VSDNN 3225 P19-VV	32	32	25	170	42	13						
19 VSDNN 3232 P19-VV	32	32	32	170	42	16.5	A5	VV8	VG8L	D2	3	
VSDNN 4040 S19-VV	40	40	40	250	50	21						
VSDNN 4040 S25-VV	40	40	40	250	50	21						
25 VSDNN 4040 S25-VV	40	40	40	250	50	21	Y8	VV9	VG9	D4	4	

CODE	H	H1	B	L1	L2	F		#					
12 VSDNN 2020 K12-VL	20	20	20	125	30	10.3	A4	VL5	VL5P	LE5	-	D1	VS5
VSDNN 2525 M12-VL	25	25	25	150	32	12.8							
VSDNN 3225 P12-VL	32	32	25	170	35	12.8							
15 VSDNN 2525 M15-VL	25	25	25	150	32	12.8	Y1	VL6	VL6P	LE6	-	D5	VS6
VSDNN 3225 P19-VL	32	32	25	170	42	13							
19 VSDNN 3232 P19-VLV	32	32	32	170	42	16.5	A5	VL8	LE8	VLG8	D2	VS8	
VSDNN 4040 S19-VLV	40	40	40	250	50	21							
VSDNN 4040 S25-VLV	40	40	40	250	50	21							
25 VSDNN 4040 S25-VLV	40	40	40	250	50	21	Y8	VL9	LE9	VLG9	D4	SE9	

Specific screw for insert CBN, PCD o CERAMICS WITH HOLE

INSERT from 25: Tool for insert SN.2509 – For using the insert SN.2507 order separately the support Y8H

NEGATIVE INSERT TN	INSERTS TN..1103 TN..1604 TN..2204 TN..2706 TN..3307	EXTERNAL TURNING 91°
-------------------------------------	---	---------------------------------------

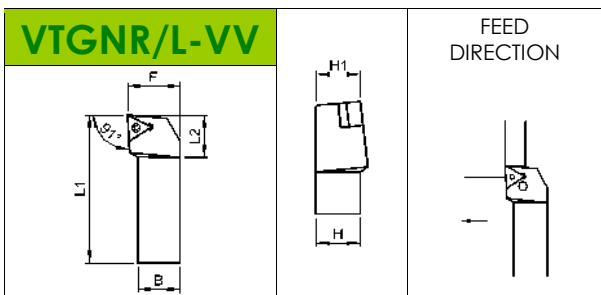

V-BLOCK SYSTEM • VTGNR/L-VV is Patent Tool Holder

CODE	H	H1	B	L1	L2	F		#				
16 VTGNR/L 1616 H16-VV	16	16	16	100	25	20	A6	VV4	VV4P	VG4C	D3	2
VTGNR/L 2020 K16-VV	20	20	20	125	25	25						
VTGNR/L 2525 M16-VV	25	25	25	150	32	32						
VTGNR/L 3225 P16-VV	32	32	25	170	35	32						
22 VTGNR/L 2525 M22-VV	25	25	25	150	32	32	A7	VV5	VV5P	VG5C	D1	2.5
VTGNR/L 3225 P22-VV	32	32	25	170	35	32						
VTGNR/L 3232 P22-VV	32	32	32	170	35	40						
27 VTGNR/L 3232 P27-VV	32	32	32	170	42	40	H1	VV6	VV6P	VG6	D5	
VTGNR/L 4040 S27-VV	40	40	40	250	40	50						
33 VTGNR/L 4040 S33-VV	40	40	40	250	50	50	H6	VV8	VG8L	H7	3	
VTGNR/L 5050 T33-VV	50	50	50	300	50	60						

Specific screw for insert CBN, PCD o CERAMICS WITH HOLE

NEGATIVE INSERT TN	INSERTS TN..1604 TN..2204 TN..2706 TN..3307	EXTERNAL TURNING 93°
--	--	--

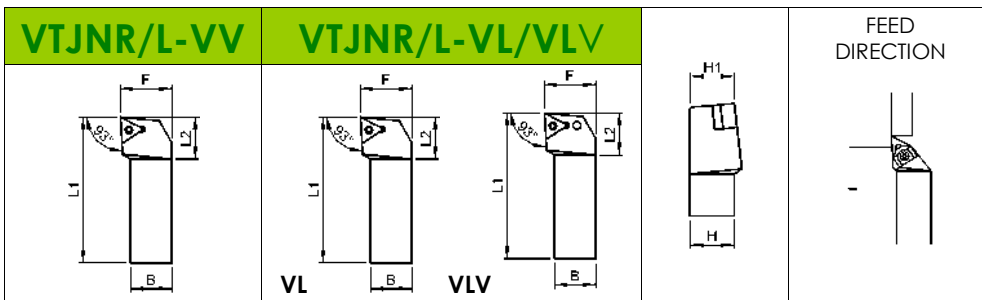

THE DRAWINGS RAPPRESENT RIGHT TOOLS • ANGLE OF INCLINATION = -6° • SUPERIOR RELIEF ANGLE = -6°

V-BLOCK SYSTEM • VTJNR/L-VV is Patent Tool Holder

∠	CODE	H	H1	B	L1	L2	F				#				
16	VTJNR/L 1616 H16-VV	16	16	16	100	25	20	A6	VV4	VV4P	VG4C	D3	2		
	VTJNR/L 2020 K16-VV	20	20	20	125	25	25								
	VTJNR/L 2525 M16-VV	25	25	25	150	32	32								
	VTJNR/L 3225 P16-VV	32	32	25	170	35	32								
22	VTJNR/L 2525 M22-VV	25	25	25	150	32	32	A7	VV5	VV5P	VG5C	D1	2.5		
	VTJNR/L 3225 P22-VV	32	32	25	170	35	32								
	VTJNR/L 3232 P22-VV	32	32	32	170	35	40								
27	VTJNR/L 3232 P27-VV	32	32	32	170	35	40	H1	VV6	VV6P	VG6	D5	3		
	VTJNR/L 4040 S27-VV	40	40	40	250	40	50								
33	VTJNR/L 4040 S33-VV	40	40	40	250	50	50	H6	VV8	VG8L	H7	3			
	VTJNR/L 5050 T33-VV	50	50	50	300	50	60								

Specific screw for insert CBN, PCD o CERAMICS WITH HOLE

V-BLOCK SYSTEM • VTJNR/L-VL/VLV are Patent Tool Holder

∠	CODE	H	H1	B	L1	L2	F				#					
16	VTJNR/L 2020 K16-VL	20	20	20	125	25	25	A6	VL4	VL4P	LE4	-	D3	VS4	2	
	VTJNR/L 2525 M16-VL	25	25	25	150	32	32									
	VTJNR/L 3225 P16-VL	32	32	25	170	35	32									
22	VTJNR/L 2525 M22-VL	25	25	25	150	32	32	A7	VL5	VL5P	LE5	-	D1	VS5	2.5	
	VTJNR/L 3225 P22-VL	32	32	25	170	35	32									
	VTJNR/L 3232 P22-VL	32	32	32	170	35	40									
27	VTJNR/L 3232 P27-VL	32	32	32	170	35	40	H1	VL6	VL6P	LE6	-	D5	VS6	3	
	VTJNR/L 4040 S27-VL	40	40	40	250	40	50									
33	VTJNR/L 4040 S33-VLV	40	40	40	250	50	50	H6	VL8	LE8	VLG8	D2	VS8	3		
	VTJNR/L 5050 T33-VLV	50	50	50	300	50	60									

Specific screw for insert CBN, PCD o CERAMICS WITH HOLE

NEGATIVE INSERT
TN

INSERTS TN..1103
TN..1604
TN..2204
TN..2706
TN..3307

EXTERNAL TURNING
91°

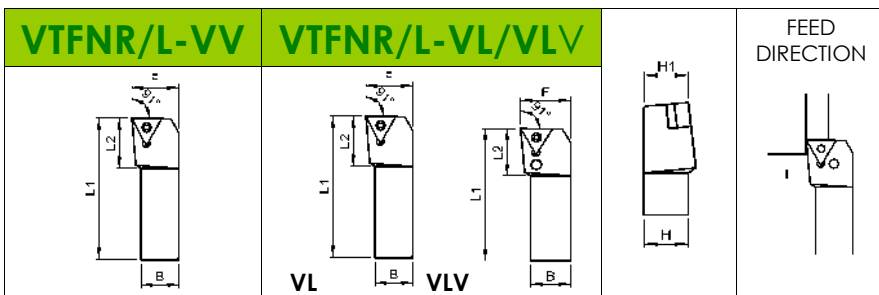

THE DRAWINGS RAPPRESENT RIGHT TOOLS • ANGLE OF INCLINATION = -6° • SUPERIOR RELIEF ANGLE = -6°

V-BLOCK SYSTEM • VTFNR/L-VV is Patent Tool Holder

CODE	H	H1	B	L1	L2	F			#				
16	VTFNR/L 1616 H16-VV	16	16	16	100	25	20	A6	VV4	VV4P	VG4C	D3	2
	VTFNR/L 2020 K16-VV	20	20	20	125	25	25						
	VTFNR/L 2525 M16-VV	25	25	25	150	32	32						
	VTFNR/L 3225 P16-VV	32	32	25	170	35	32						
22	VTFNR/L 2525 M22-VV	25	25	25	150	32	32	A7	VV5	VV5P	VG5C	D1	2.5
	VTFNR/L 3225 P22-VV	32	32	25	170	35	32						
	VTFNR/L 3232 P22-VV	32	32	32	170	35	40						
27	VTFNR/L 3232 P27-VV	32	32	32	170	35	40	H1	VV6	VV6P	VG6	D5	
	VTFNR/L 4040 S27-VV	40	40	40	250	40	50						
33	VTFNR/L 4040 S33-VV	40	40	40	250	50	50	H6	VV8		VG8L	H7	3
	VTFNR/L 5050 T33-VV	50	50	50	300	50	60						

Vite specifica per inserto CBN, PCD o CERAMICO con foro

V-BLOCK SYSTEM • VTFNR/L-VL-VLV are Patent Tool Holder

CODE	H	H1	B	L1	L2	F			#						
16	VTFNR/L 2020 K16-VL	20	20	20	125	25	25	A6	VL4	VL4P	LE4	-	D3	VS4	2
	VTFNR/L 2525 M16-VL	25	25	25	150	32	32								
	VTFNR/L 3225 P16-VL	32	32	25	170	35	32								
22	VTFNR/L 2525 M22-VL	25	25	25	150	32	32	A7	VL5	VL5P	LE5	-	D1	VS5	2.5
	VTFNR/L 3225 P22-VL	32	32	25	170	35	32								
	VTFNR/L 3232 P22-VL	32	32	32	170	35	40								
27	VTFNR/L 3232 P27-VL	32	32	32	170	35	40	H1	VL6	VL6P	LE6	-	D5	VS6	
	VTFNR/L 4040 S27-VL	40	40	40	250	40	50								
33	VTFNR/L 4040 S33-VLV	40	40	40	250	50	50	H6	VL8		LE8	VLG8	D2	VS8	3
	VTFNR/L 5050 T33-VLV	50	50	50	300	50	60								

Specific screw for insert CBN, PCD o CERAMICS WITH HOLE

NEGATIVE INSERT
VN

INSERTS VN..1604

EXTERNAL TURNING
93°

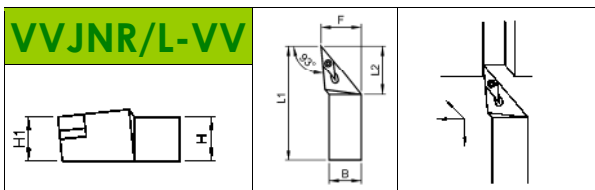

THE DRAWINGS RAPPRESENT RIGHT TOOLS • ANGLE OF INCLINATION = -6° • SUPERIOR RELIEF ANGLE = -6°

V-BLOCK SYSTEM • VVJNR/L-VV is Patent Tool Holder

CODE	H	H1	B	L1	L2	F			#				
16	VVJNR/L 2020 K16-VV	20	20	20	125	35	25	W1	VV4	VV4P	VG4L	D31	2
	VVJNR/L 2525 M16-VV	25	25	25	150	37	32						
	VVJNR/L 3225 P16-VV	32	32	25	170	42	32						

Specific screw for insert CBN, PCD o CERAMICS WITH HOLE

NEGATIVE INSERT **INSERTS VN..1604** **EXTERNAL TURNING**
VN **72.5°**

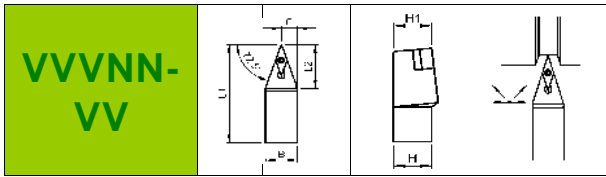

THE DRAWINGS RAPPRESENT RIGHT TOOLS • ANGLE OF INCLINATION = -13° • SUPERIOR RELIEF ANGLE = -4°

V-BLOCK SYSTEM • VVVNN/L-VV is Patent Tool Holder

	CODE	H	H1	B	L1	L2	F						
16	VVVNN 2020 K16-VV	20	20	20	125	35	10.6	W1	VV4	VV4P	VG4L	D31	2
	VVVNN 2525 M16-VV	25	25	25	150	37	13.1						
	VVVNN 3225 P16-VV	32	32	25	170	42	13.1						

NEGATIVE INSERT **INSERTS WN..0604** **EXTERNAL TURNING**
WN **WN..0804** **95°**

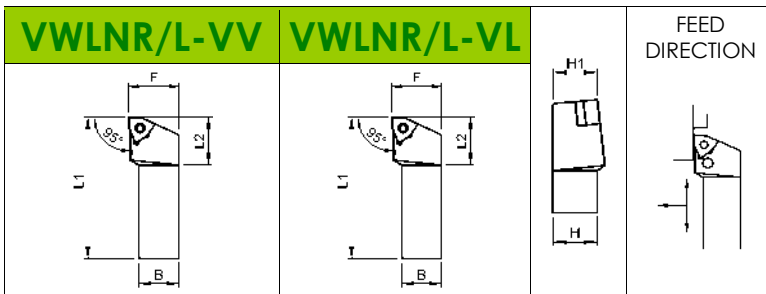

THE DRAWINGS RAPPRESENT RIGHT TOOLS • ANGLE OF INCLINATION = -6° • SUPERIOR RELIEF ANGLE = -6°

V-BLOCK SYSTEM • VWLNR/L-VV is Patent Tool Holder

	CODE	H	H1	B	L1	L2	F						
06	VWLNR/L 1616 H06-VV	16	16	16	100	20	20	A13	VV4	VV4P	VG4	D3	2
	VWLNR/L 2020 K06-VV	20	20	20	125	25	25						
	VWLNR/L 2525 M06-VV	25	25	25	150	32	32						
08	VWLNR/L 2020 K08-VV	20	20	20	125	30	25	A12	VV5	VV5P	VG5	D1	2.5
	VWLNR/L 2525 M08-VV	25	25	25	150	32	32						
	VWLNR/L 3232 P08-VV	32	32	32	170	35	40						

Specific screw for insert CBN, PCD o CERAMICS WITH HOLE

V-BLOCK SYSTEM • VWLNR/L-VV is Patent Tool Holder

	CODE	H	H1	B	L1	L2	F						
08	VWLNR/L 2020 K08-VL	20	20	20	125	30	25	A12	VL5	VL5P	LE5	D1	2.5
	VWLNR/L 2525 M08-VL	25	25	25	150	32	32						
	VWLNR/L 3232 P08-VL	32	32	32	170	35	40						

Specific screw for insert CBN, PCD o CERAMICS WITH HOLE

POSITIVE INSERT WITH HOLE INSERTS **DC..0702**
DC **DC..11T3** **EXTERNAL TURNING**
93°

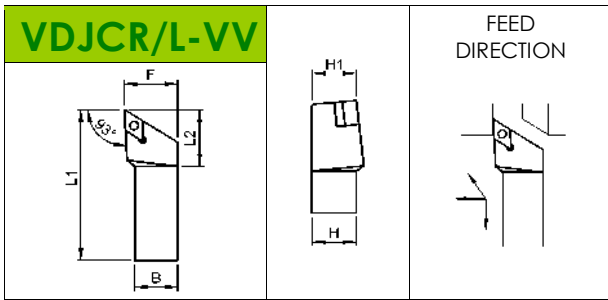

THE DRAWINGS RAPPRESENT RIGHT TOOLS • ANGLE OF INCLINATION = -0° • SUPERIOR RELIEF ANGLE = -0°

V-BLOCK SYSTEM • VDJCR/L-VV is Patent Tool Holder

	CODE	H	H1	B	L1	L2	F		#			
11	VDJCR/L 1616 H11-VV	16	16	16	100	25	20	W2	VV45C	VG4	-	2
	VDJCR/L 2020 K11-VV	20	20	20	125	25	25		VV45	VG4L	D31	
	VDJCR/L 2525 M11-VV	25	25	25	150	32	32					

Specific screw for insert CBN, PCD o CERAMICS WITH HOLE

POSITIVE INSERT WITH HOLE INSERTS **DC..0702**
DC **DC..11T3** **EXTERNAL TURNING**
62.5°

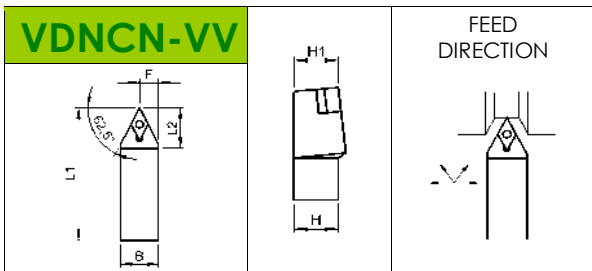

• ANGLE OF INCLINATION = -0° • SUPERIOR RELIEF ANGLE = -0°

V-BLOCK SYSTEM • VDNCN/L-VV is Patent Tool Holder

	CODE	H	H1	B	L1	L2	F		#			
11	VDNCN 1616 H11-VV	16	16	16	100	25	8.5	W2	VV45C	VG4	-	2
	VDNCN 2020 K11-VV	20	20	20	125	25	10.5		VV45	VG4L	D31	
	VDNCN 2525 M11-VV	25	25	25	150	25	13					

POSITIVE INSERT WITH HOLE INSERTS **VB..1102**
VB **VB..1604** **EXTERNAL TURNING**
93°

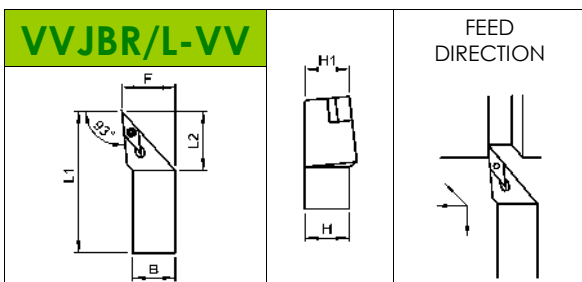

THE DRAWINGS RAPPRESENT RIGHT TOOLS • ANGLE OF INCLINATION = -0° • SUPERIOR RELIEF ANGLE = -0°

V-BLOCK SYSTEM • VVVJBR/L-VV is Patent Tool Holder

	CODE	H	H1	B	L1	L2	F		#			
16	VVJBR/L 2020 K16-VV	20	20	20	125	35	25	W1	VV45	VG4L	D31	2
	VVJBR/L 2525 M16-VV	25	25	25	150	37	32					
	VVJBR/L 3225 P16-VV	32	32	25	170	42	32					

Specific screw for insert CBN, PCD o CERAMICS WITH HOLE

POSITIVE INSERT WITH HOLE INSERTS **VB..1102**
VB **VB..1604** **EXTERNAL TURNING**
72.5°

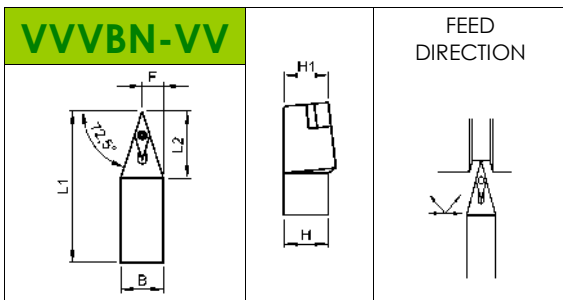

THE DRAWINGS RAPPRESENT RIGHT TOOLS • ANGLE OF INCLINATION = -0° • SUPERIOR RELIEF ANGLE = -0°

V-BLOCK SYSTEM • VVBN/L-VV is Patent Tool Holder

	CODE	H	H1	B	L1	L2	F		#			
16	VVBN 2020 K16-VV	20	20	20	125	32	10.6	W1	VV45	VG4L	D31	2
	VVBN 2525 M16-VV	25	25	25	150	32	13.1					
	VVBN 3225 P16-VV	32	32	25	170	32	13.1					

Specific screw for insert CBN, PCD o CERAMICS WITH HOLE

POSITIVE INSERT WITH HOLE INSERTS **VB..1604** **EXTERNAL TURNING**
VB **117.5°**

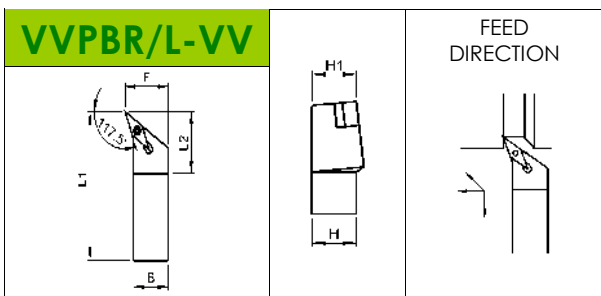

THE DRAWINGS RAPPRESENT RIGHT TOOLS • ANGLE OF INCLINATION = -0° • SUPERIOR RELIEF ANGLE = -0°

V-BLOCK SYSTEM • VVPBR/L-VV is Patent Tool Holder

	CODE	H	H1	B	L1	L2	F		#			
16	VVPBR/L 2020 K16-VV	20	20	20	125	35	25	W1	VV45	VG4L	D31	2
	VVPBR/L 2525 M16-VV	25	25	25	150	37	32					

POSITIVE INSERT WITH HOLE INSERTS **VC..1604** **EXTERNAL TURNING**
VC **117.5°**

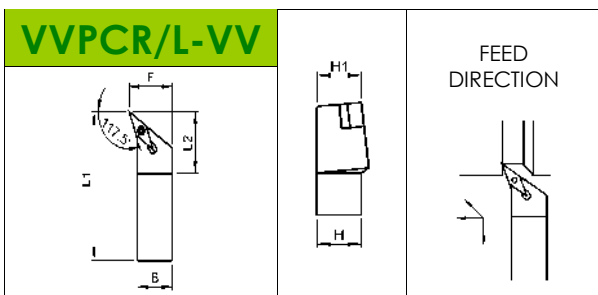

THE DRAWINGS RAPPRESENT RIGHT TOOLS • ANGLE OF INCLINATION = -0° • SUPERIOR RELIEF ANGLE = -0°

V-BLOCK SYSTEM • VVPCR/L-VV is Patent Tool Holder

	CODE	H	H1	B	L1	L2	F		#			
16	VVPCR/L 2020 K16-VV	20	20	20	125	35	25	W1	VV45	VG4L	D31	2
	VVPCR/L 2525 M16-VV	25	25	25	150	37	32					

Specific screw for insert CBN, PCD o CERAMICS WITH HOLE

POSITIVE INSERT WITH HOLE INSERTS VC..1103
VC..1604 **EXTERNAL TURNING**
VC **93°**

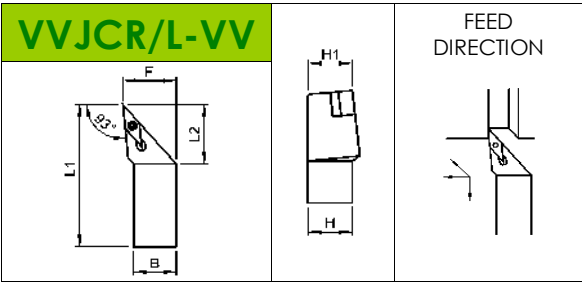

THE DRAWINGS RAPPRESENT RIGHT TOOLS • ANGLE OF INCLINATION = -0° • SUPERIOR RELIEF ANGLE = -0°

V-BLOCK SYSTEM • VVJCR/L-VV is Patent Tool Holder

	CODE	H	H1	B	L1	L2	F			#			
16	VVJCR/L 2020 K16-VV	20	20	20	125	32	25	W1	VV45		VG4L	D31	2
	VVJCR/L 2525 M16-VV	25	25	25	150	32	32						
	VVJCR/L 3225 P16-VV	32	32	25	170	32	32						

Specific screw for insert CBN, PCD o CERAMICS WITH HOLE

POSITIVE INSERT WITH HOLE INSERTI VC..1103
VC..1604 **EXTERNAL TURNING**
VC **72.5°**

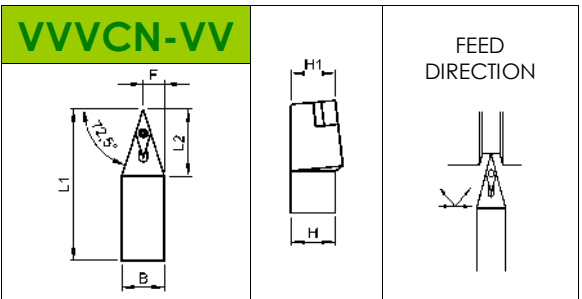

THE DRAWINGS RAPPRESENT RIGHT TOOLS • ANGLE OF INCLINATION = -0° • SUPERIOR RELIEF ANGLE = -0°

V-BLOCK SYSTEM • VVVCN/L-VV is Patent Tool Holder

	CODE	H	H1	B	L1	L2	F			#			
16	VVVCN 2020 K16-VV	20	20	20	125	32	10.6	W1	VV45		VG4L	D31	2
	VVVCN 2525 M16-VV	25	25	25	150	32	13.1						
	VVVCN 3225 P16-VV	32	32	25	170	32	13.1						

Specific screw for insert CBN, PCD o CERAMICS WITH HOLE

INTERNAL TURNING V-BLOCK SYSTEM

Page

TOOLS FOR NEGATIVE INSERTS

Insert CN	20-21
Insert DN	21
Insert SN	22
Insert TN	22
Insert WN	23

INTERNAL TURNING CLAMPING SYSTEM

S 25TPCLNR 12

10 11 8 1 2 3 4 5 9

Clamping System

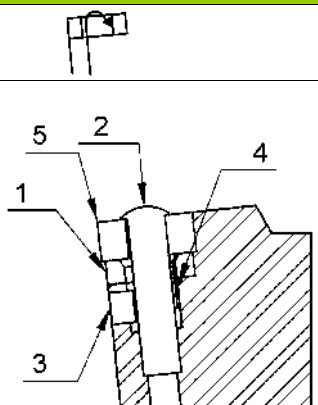
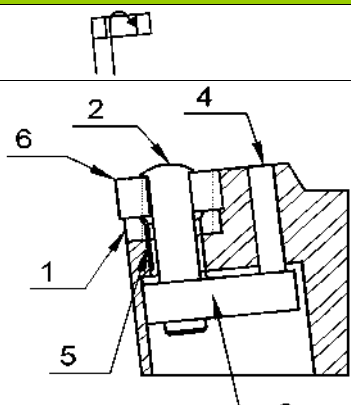
VV-Block	VL/VLV-Block
 <p>1 BASE 2 SCREW 3 GRAIN 4 SPLUG 5 INSERT</p>	 <p>1 BASE 2 SCREW 3 LEVER 4 GRAIN 5 SPLUG 6 INSERT</p>

NEGATIVE INSERT	INSERTS CN..1204 CN..1606 CN..1906	INTERNAL TURNING
CN		95°

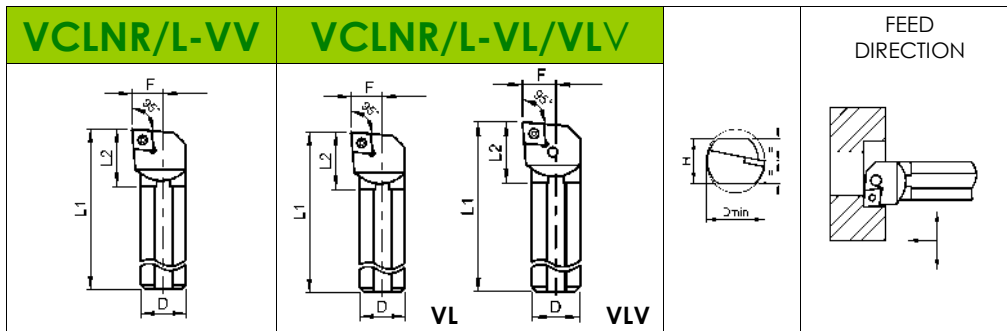

THE DRAWINGS RAPPRESENT RIGHT TOOLS • ANGLE OF INCLINATION = Ω ° • SUPERIOR RELIEF ANGLE = -6°

WITH COOLANT • V-BLOCK SYSTEM is Patent Tool Holder

	CODE	D	H	L1	L2	F	D Min	Ω							
12	A20Q VCLNR/L 12-VV	20	18	180	38	12.5	25	-16°	-	VV5X	VV5XP	VG4	-	2	D1
	A25R VCLNR/L 12-VV	25	23	200	42	16.5	32	-16°	-	VV5X	VV5XP	VG4L			
	A32S VCLNR/L 12-VV	32	30	250	49	22	40	-12°	A1	VVi5	VVi5P	VG5C	2.5		
	A40T VCLNR/L 12-VV	40	37	300	56	26	50	-11°	A1	VVi5	VVi5P	VG5			
	A50U VCLNR/L 12-VV	50	47	350	63	35	63	-11°	A1	VVi5	VVi5P	VG5			
16	A40T VCLNR/L 16-VV	40	37	300	56	26	50	-11°	Y2	VVi6	VVi6P	VG5	D5		
	A50U VCLNR/L 16-VV	50	47	350	63	34	63	-11°							

Specific screw for insert CBN, PCD o CERAMICS WITH HOLE

WITH COOLANT • VL-BLOCK SYSTEM is Patent Tool Holder

	CODE	D	H	L1	L2	F	D Min	Ω								
12	A20Q VCLNR/L 12-VL	20	18	180	38	12.5	25	-16°	-	VL5C	VL5CP	LE5	-	-	VS5C	2
	A25R VCLNR/L 12-VL	25	23	200	42	16.5	32	-16°								
	A32S VCLNR/L 12-VL	32	30	250	49	22	40	-12°								

Specific screw for insert CBN, PCD o CERAMICS WITH HOLE

VL/VLV BLOCK SYSTEM are Patent Tool Holder

	CODE	D	H	L1	L2	F	D Min	Ω								
12	S40V VCLNR/L 12-VL	40	37	400	56	26	50	-11°	A1	VL5	VL5P	LE5	-	D1	VS5	2.5
	S50W VCLNR/L 12-VL	50	47	450	70	35	63	-11°								
	S60Y VCLNR/L 12-VL	60	57	500	80	35	70	-11°								
16	S40V VCLNR/L 16-VL	40	37	400	56	25.5	50	-11°	Y2	VL6	VL6P	LE6	-	130	VS6	
	S50W VCLNR/L 16-VL	50	47	450	70	34	63	-11°								
	S60Y VCLNR/L 16-VL	60	57	500	80	35	70	-11°								
19	S50W VCLNR/L 19-VLV	50	47	450	70	33	63	-11°	A2	VL8C	LE8	VLG8C	131	VS8	3	
	S60Y VCLNR/L 19-VLV	60	57	500	80	35	70	-11°								

Specific screw for insert CBN, PCD o CERAMICS WITH HOLE

NEGATIVE INSERT **INSERTS** **CN..1204** **INTERNAL TURNING**
CN **CN..1606** **15°**
CN..1906

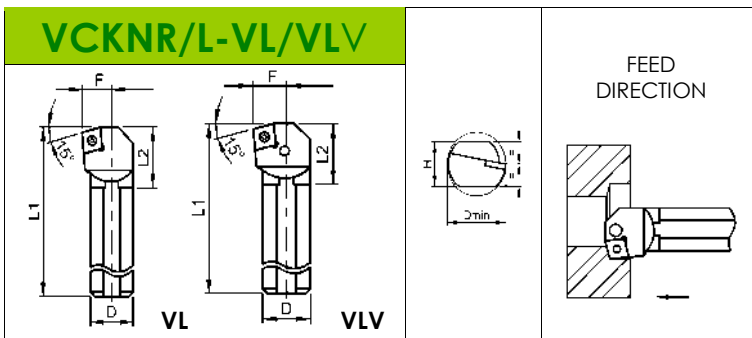

THE DRAWINGS RAPPRESENT RIGHT TOOLS • ANGLE OF INCLINATION = Ω ° • SUPERIOR RELIEF ANGLE = -6°

WITH COOLANT • VL-BLOCK SYSTEM is Patent Tool Holder

	CODE	D	H	L1	L2	F	Dmin	Ω			#					
12	A20Q VCKNR/L 12-VL	20	18	180	38	12.5	25	-16°	-	VL5C	VL5CP	LE5	-	-	VS5C	2
	A25R VCKNR/L 12-VL	25	23	200	42	16.5	32	-16°	-	VL5	VL5P	LE5	-	-	VS5	2.5
	A32S VCKNR/L 12-VL	32	30	250	49	22	40	-12°	A1	VL5	VL5P	LE5	-	D1	VS5	2.5

VL-BLOCK SYSTEM is Patent Tool Holder

	CODE	D	H	L1	L2	F	Dmin	Ω			#				
12	S40V VCKNR/L 12-VL	40	37	400	56	26	50	-11°	A1	VL5	VL5P	LE5	-	D1	VS5
	S50W VCKNR/L 12-VL	50	47	450	70	35	63	-11°							
16	S40V VCKNR/L 16-VL	40	37	400	56	25.5	50	-11°	Y2	VL6	VL6P	LE6	-	130	VS6
	S50W VCKNR/L 16-VL	50	47	450	70	34	63	-11°							
19	S50W VCKNR/L 19-VLV	50	47	450	70	35	63	-11°	A2	VL8C	LE8	VLG8C	131	VS8	3

NEGATIVE INSERT **INSERTS** **DN..1104** **INTERNAL TURNING**
DN **DN..1506** **93°**

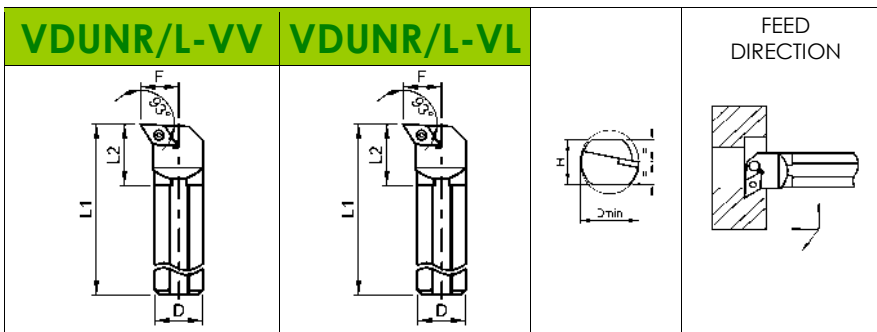

THE DRAWINGS RAPPRESENT RIGHT TOOLS • ANGLE OF INCLINATION = Ω ° • SUPERIOR RELIEF ANGLE = -6°

WITH COOLANT • VV-BLOCK SYSTEM is Patent Tool Holder

	CODE	D	H	L1	L2	F	Dmin	Ω			#				
15	A32S VDUNR/L 15-VV	32	30	250	49	22	40	-14°	A3	VVI5	VVI5P	VG5	-	D1	2.5
	A40T VDUNR/L 15-VV	40	37	300	56	27	50	-11°							
	A50U VDUNR/L 15-VV	50	47	350	63	35	63	-11°							

WITH COOLANT TOOLS • VL-BLOCK SYSTEM is Patent Tool Holder

	CODE	D	H	L1	L2	F	Dmin	Ω			#				
11	A20Q VDUNR/L 11-VL	20	18	180	38	13	25	-14°	-	VL4c	VL4CP	LE4	-	VS4	2
	A25R VDUNR/L 11-VL	25	23	200	42	17	32	-12°							
15	A25R VDUNR/L 15-VL	25	23	200	42		32	-16°	-	VL5	VL5P	LE5	-	VS4	2.5
	A32S VDUNR/L 15-VL	32	30	250	49	22	40	-14°							

VL-BLOCK SYSTEM is Patent Tool Holder

	CODE	D	H	L1	L2	F	Dmin	Ω			#				
15	S40V VDUNR/L 15-VL	40	37	400	56	25.5	50	-11°	A3	VL5L	VL5LP	LE5	D1	VS5	2.5
	S50W VDUNR/L 15-VL	50	47	450	70	33	63	-11°							
	S60Y VDUNR/L 15-VL	60	57	500	80	35	70	-11°							

Specific screw for insert CBN, PCD o CERAMICS WITH HOLE

NEGATIVE INSERT INSERTS **SN..1204** **INTERNAL TURNING**
SN **SN..1506** **75°**
SN..1906

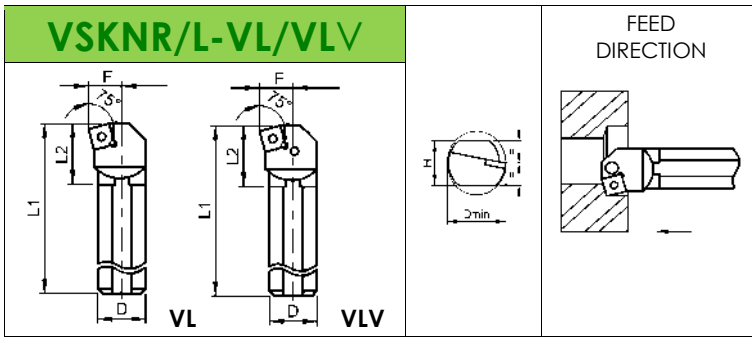

THE DRAWINGS RAPPRESENT RIGHT TOOLS • ANGLE OF INCLINATION = Ω° • SUPERIOR RELIEF ANGLE = -6°

WITH COOLANT • VL-BLOCK SYSTEM is Patent Tool Holder

	CODE	D	H	L1	L2	F	Dmin	Ω			#					
12	A20Q VSKNR/L 12-VL	20	18	180	38	12.5	25	-16°	-	VL5C	VL5P	LE5	-	-	VS5C	2
	A25R VSKNR/L 12-VL	25	23	200	42	16.5	32	-16°								
	A32S VSKNR/L 12-VL	32	30	250	49	22	40	-12°								

VL/VLV-BLOCK SYSTEM is Patent Tool Holder

	CODE	D	H	L1	L2	F	Dmin	Ω			#					
12	S40V VSKNR/L 12-VL	40	37	400	56	25.5	50	-11°	A4	VL5	VL5P	LE5	-	D1	VS5	2.5
15	S40V VSKNR/L 15-VL	40	37	400	56	25.5	50	-11°	Y1	VL6	VL6P	LE6	-	130	VS6	
		S50W VSKNR/L 15-VL	50	47	450	70	33	63								
19	S50W VSKNR/L 19-VLV	50	47	450	70	33	63	-11°	A5	VL8C	LE8	VLG8C	131	VS8	3	

Specific screw for insert CBN, PCD o CERAMICS WITH HOLE

NEGATIVE INSERT INSERTS **TN..1604** **INTERNAL TURNING**
TN **TN..2204** **91°**

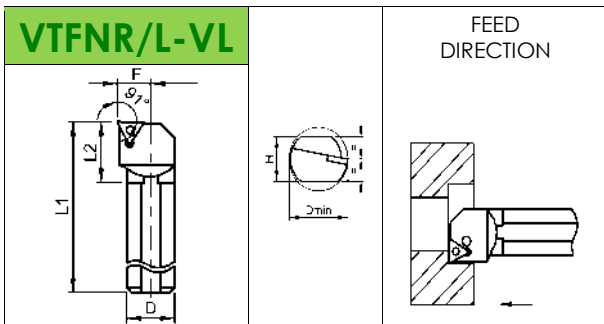

THE DRAWINGS RAPPRESENT RIGHT TOOLS • ANGLE OF INCLINATION = Ω° • SUPERIOR RELIEF ANGLE = -6°

VL-BLOCK SYSTEM is Patent Tool Holder

	CODE	D	H	L1	L2	F	Dmin	Ω			#					
16	A20Q VTFNR/L 16-VL	20	18	180	38	13	25	-14°	-	VL4C	VL4CP	LE4	-	VS4	2	
	A25R VTFNR/L 16-VL	25	23	200	42	16.5	32	-12°								
	A32S VTFNR/L 16-VL	32	30	250	49	22	40	-12°								
	S40V VTFNR/L 16-VL	40	37	400	56	26	50	-11°								A6
22	S40V VTFNR/L 22-VL	40	37	400	56	25.5	50	-11°	A7	VL5	VL5P	LE5	D1	VS5	2.5	
	S50W VTFNR/L 22-VL	50	47	450	70	33	63	-11°								

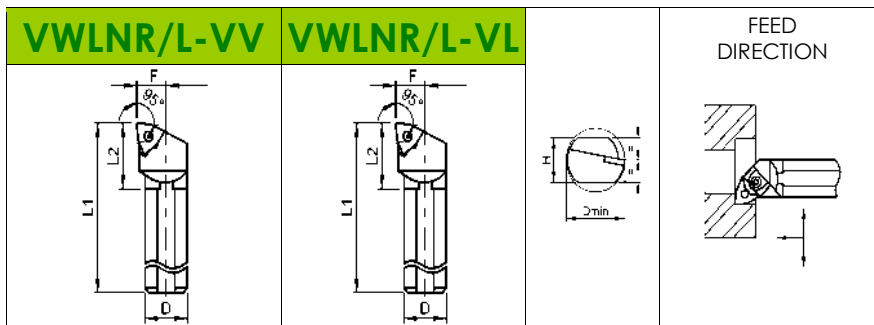

Specific screw for insert CBN, PCD o CERAMICS WITH HOLE

NEGATIVE INSERT WN	INSERTS WN..0804	INTERNAL TURNING 95°
-------------------------------------	-------------------------	---------------------------------------







THE DRAWINGS RAPPRESENT RIGHT TOOLS • ANGLE OF INCLINATION = Ω ° • SUPERIOR RELIEF ANGLE = -6°

WITH COOLANT • VV-BLOCK SYSTEM is Patent Tool Holder

	CODE	D	H	L1	L2	F	Dmin	Ω						
08	A20Q VWLNR/L 08-VV	20	18	180	38	13	25	-12°	-	VV5X	VV5XP	VG4	-	2
	A25R VWLNR/L 08-VV	25	23	200	42	17	32	-12°	-	VV5X	VV5XP	VG4L		
	A32S VWLNR/L 08-VV	32	30	250	49	22	40	-11°	A12	VV15	VV15P	VG5C	D1	2.5
	A40T VWLNR/L 08-VV	40	37	300	56	27	50	-11°						
	A50U VWLNR/L 08-VV	50	47	350	63	35	63	-11°						







Specific screw for insert CBN, PCD o CERAMICS WITH HOLE

WITH COOLANT • VL-BLOCK SYSTEM is Patent Tool Holder

	CODE	D	H	L1	L2	F	Dmin	Ω							
08	A20Q VWLNR/L 08-VL	20	18	180	38	12.5	25	-14°	-	VL5C	VL5CP	LE5	-	VS5C	2
	A25R VWLNR/L 08-VL	25	23	200	42	16.5	32	-12°							
	A32S VWLNR/L 08-VL	32	30	250	49	21.5	40	-12°	A12	VL5	VL5P	LE5	D1	VS5	2.5

Specific screw for insert CBN, PCD o CERAMICS WITH HOLE

VL-BLOCK SYSTEM is Patent Tool Holder

	CODE	D	H	L1	L2	F	Dmin	Ω							
08	S40V VWLNR/L 08-VL	40	37	400	56	25.5	50	-11°	A12	VL5	VL5P	LE5	D1	VS5	2.5
	S50W VWLNR/L 08-VL	50	47	450	70	33	63	-11°							
	S60Y VWLNR/L 08-VL	60	57	500	80	35	70	-11°							

Specific screw for insert CBN, PCD o CERAMICS WITH HOLE

ADJUSTABLE BORING		Page
ADJUSTABLE BORING BARS		
RAI (Inserts TC..)		26-27
MTE (Inserts CC..)		27
MISURAI Measuring Device		28
RAI – MTE Boring Bars SET		29
ADJUSTABLE HEAD		
RAIMAX		30-31-32
RAIMAX SET		33
RAIMAX2		34
RAIMAX2 SET		35



ADJUSTABLE BORING BARS FOR INTERNAL BORING

SIMPLY AND EFFICIENT

THE CENTESIMAL
REGULATION OF THE
DIAMETER ALLOWS,
WITH THE SAME
TOOL, TO OBTAIN
ALL THE
DIMENSIONS INSIDE
THE DIAMETER OF
REFERENCE.

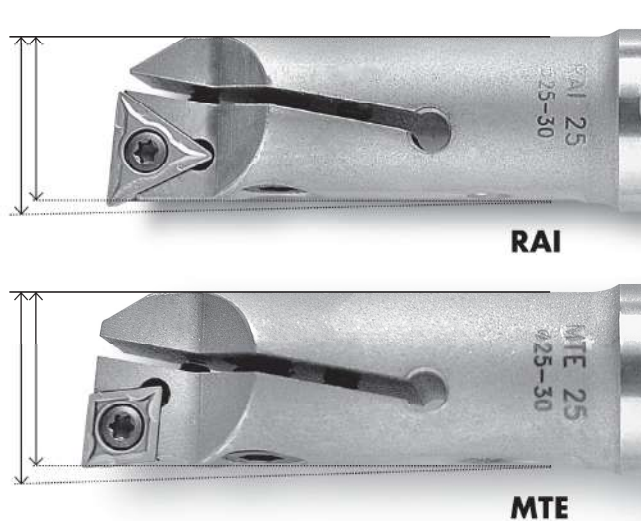

INSTRUCTIONS FOR ADJUSTING RAI - MTE

- 1_ Losen the locking grain (2) and the screw (3)
- 2_ Change the diameter of reaming by rotating the adjusting grain (1) and reading the centesimal variation on the dial of the comparator
- 3_ Awarded your size , first lock the screw (3) then the grain (2)

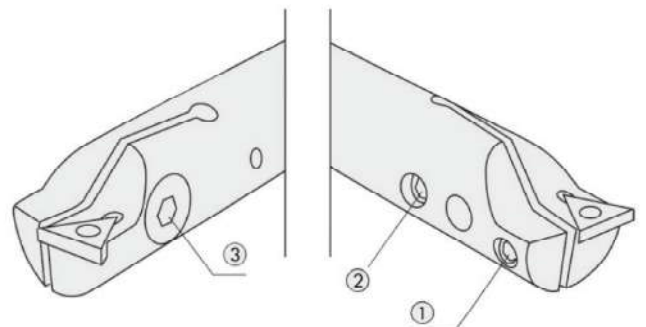

RAI

INSERTS WCMX 0201
TBGH 0601
TPGX 0802/TC..0802
TC..1102
TC..16T3

ADJUSTABLE BORING BARS FOR BORING Ø6-50

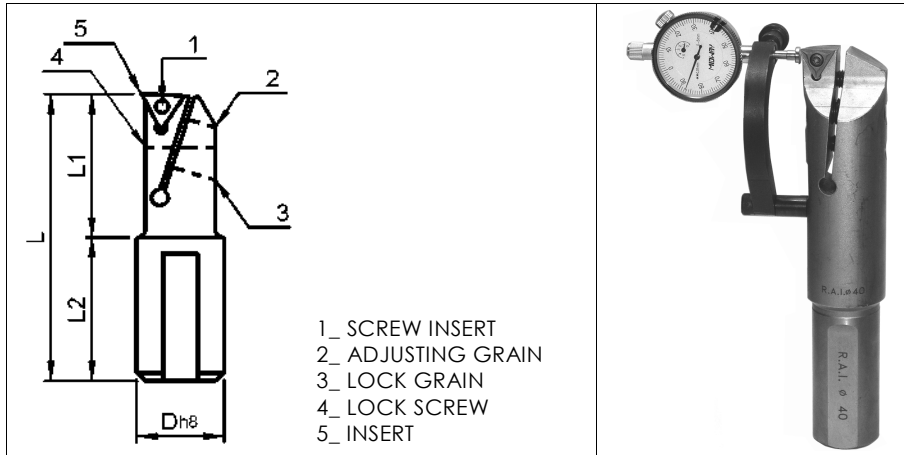

RAI • STANDARD SERIES

	CODE	BORING	L1	L	L2	D	1	2	3	4	INSERT			
02	RAI Ø6	6-7	20	85	65	8	V24	TX6	RE11	G15	0.89	BL11	TX6	WCMT 0201
06	RAI Ø7	7-8	25	90	65	8	V20	TX6	RE9	G13	1.5	BL9	TX7	TBGH 0601..L
	RAI Ø8	8-10	25	90	65	8			RE10	G14	1.5	BL10	TX9	
08	RAI Ø10	10-12	30	100	70	10	V20	TX6	RE0	G0	1.5	BL0	TX15	TPGX 0802..L TC..0802
	RAI Ø12	12-15	40	105	65	12			RE1	G3	1.5	BL1	TX20	
	RAI Ø15	15-20	50	110	60	16			RE2	G4	2	BL2	TX25	
11	RAI Ø20	20-25	60	120	60	20	V25	TX7	RE3	G5	2.5	BL3	5	TC..1102
16	RAI Ø25	25-30	70	140	70	25	V4	TX15	RE4	G6	2.5	BL4	5	TC..16T3
	RAI Ø30	30-35	90	160	70	25			RE5	G7	4	BL5	6	
	RAI Ø35	35-40	100	170	70	32			RE6	G8	4	BL6	6	
	RAI Ø40	40-45	120	190	70	32			RE7	G9	4	BL7	8	
	RAI Ø45	45-50	150	220	70	32			RE8	G10	4	BL8	8	

RAI SC • SHORT SERIES

	CODE	BORING	L1	L	L2	D	1	2	3	4	INSERT				
16	RAI Ø30 SC	30-35	64	120	56	25	V4	TX15	RE5	G7	4	BL5	6	TC..16T3	
	RAI Ø35 SC	35-40	64	120	56	25			RE6	G8	4	BL6			
	RAI Ø40 SC	40-45	74	130	56	25			RE7	G9	4	BL7			8
	RAI Ø45 SC	45-50	94	150	56	25			RE8	G10	4	BL8			

RAI SL • LONG SERIES

	CODE	BORING	L1	L	L2	D	1	2	3	4	INSERT			
08	RAI Ø12 SL	12-15	60	130	70	12	V20	TX6	RE1	G3	1.5	BL1	TX20	TPGX0802..L TC..0802
	RAI Ø15 SL	15-20	70	140	70	16			RE2	G4	2	BL2	TX25	
11	RAI Ø20 SL	20-25	80	150	70	20	V25	TX7	RE3	G5	2.5	BL3	5	TC..1102
16	RAI Ø25 SL	25-30	100	170	70	25	V4	TX15	RE4	G6	2.5	BL4	5	TC..16T3
	RAI Ø30 SL	30-35	120	190	70	25			RE5	G7	4	BL5	6	
	RAI Ø35 SL	35-40	150	220	70	32			RE6	G8	4	BL6		

THE RAI BORING BARS ARE PATENTED

RAI 50

INSERTS CC..09T3
TC..16T3

ADJUSTABLE BORING BARS WITH CARTRIDGE FOR BORING Ø50-75

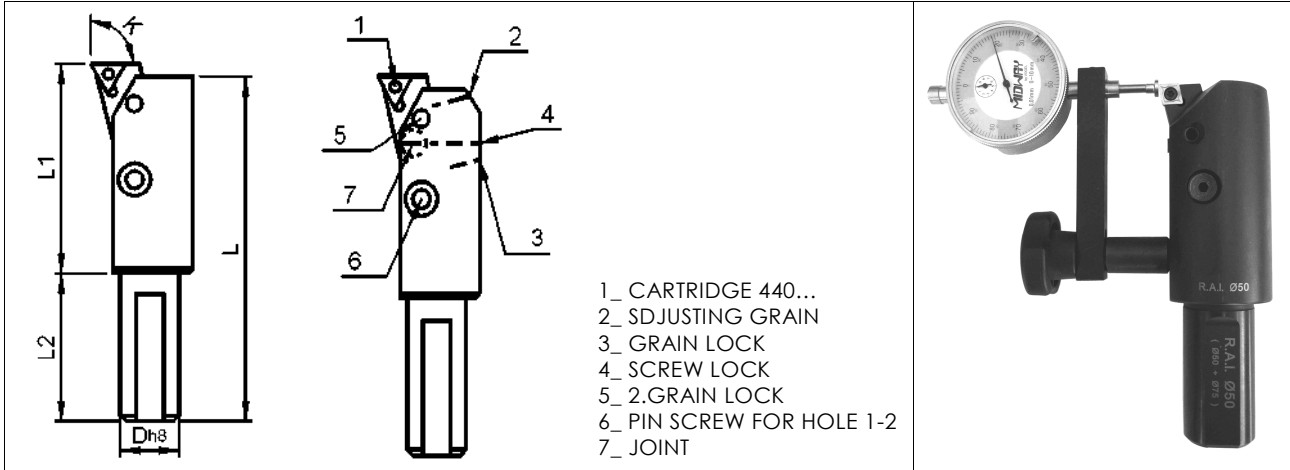

- 1_ CARTRIDGE 440...
- 2_ SDJUSTING GRAIN
- 3_ GRAIN LOCK
- 4_ SCREW LOCK
- 5_ 2.GRAIN LOCK
- 6_ PIN SCREW FOR HOLE 1-2
- 7_ JOINT

CODE	BORING	L1	L	L2	D	1	2	3	4	5	6	7		
RAI Ø50	50-75	95-97	150	60	32	440..	RE21	G21	BL21	GBL21	VP21	PA21	4	6

BORING	CARTRIDGE	HOLE	K - ANGLE
50 - 51	440..104°	1	91° - 90°
51,5 - 59	440..109°	1	94° - 90°
59,5 - 68	440..104°	2	95° - 90°
68,5 - 75	440..109°	2	96° - 91°

CARTRIDGE 440...16

CARTRIDGE 440...09

CODE	A	INSERT				CODE	A	INSERT		
440.11-16 104°	104°	TC..16T3104°	CC.. 09T3	V4C	TX15	440.31-09 104°	104°	CC..09T3	V4C	TX15
440.21-16 109°	109°	TC..16T3109°	CC.. 09T3			440.41-09 109°	109°	CC..09T3		

MTE

INSERTS CC.. 0602
CC.. 09T3

ADJUSTABLE BORING BARS FOR BORING Ø10-50

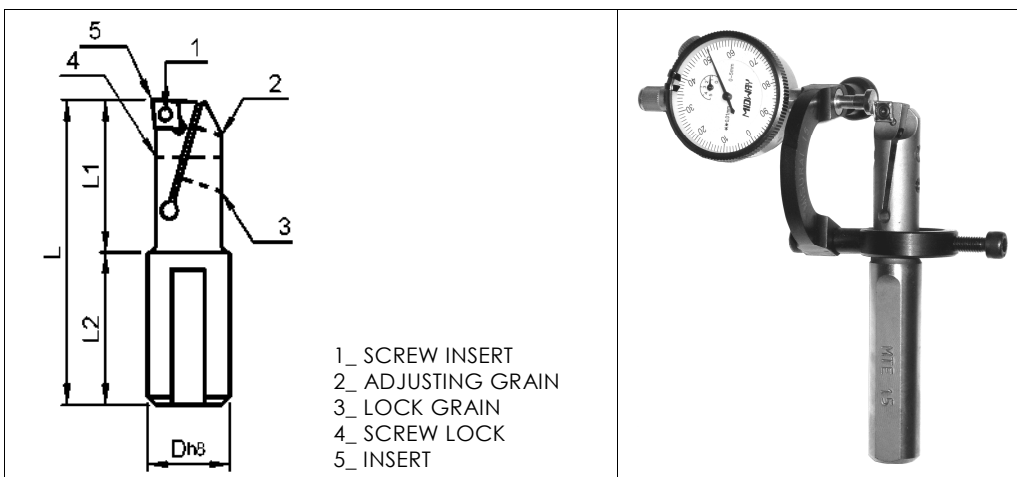



- 1_ SCREW INSERT
- 2_ ADJUSTING GRAIN
- 3_ LOCK GRAIN
- 4_ SCREW LOCK
- 5_ INSERT

	CODE	BORING	L1	L	L2	D	1		2	3		4		INSERT
06	MTE Ø10	10-12	30	100	70	10	V28	Tx7	RE1	RE0	1.5	BL0	TX15	CC..0602
	MTE Ø12	12-15	40	105	65	12			RE1	G3	1.5	BL1	TX20	
	MTE Ø15	15-20	50	110	60	16			RE2	G4	2	BL2	TX25	
	MTE Ø20	20-25	60	120	60	20			RE3	G5	2.5	BL3	5	
09	MTE Ø25	25-30	70	140	70	25	V36	Tx15	RE4	G6	2.5	BL4	5	CC..09T3
	MTE Ø30	30-35	90	160	70	25			RE5	G7	4	BL5	6	
	MTE Ø35	35-40	100	170	70	32			RE6	G8	4	BL6	6	
	MTE Ø40	40-45	120	190	70	32			RE7	G9	4	BL7	8	
	MTE Ø45	45-50	150	220	70	32			RE8	G10	4	BL8	8	

MISURAI

ADJUSTING DEVICE

FOR A CENTESIMAL ADJUSTMENT OF CUTTING DIAMETER OF RAI AND MTE BORING BARS

		CODE	BORING BARS	DIAL GAUGE	TYPE
 <p>MISURAI RING Composed of ring, perforated cylinder and centesimal dial gauge</p>	 <p>MISURAI ARM Composed of perforated cylinder, arm and centesimal dial gauge</p>	MISURAI 6-7-8+C	RAI Ø6 RAI Ø7 RAI Ø8	COM 1/100-05	RING
		MISURAI10-12+C	RAI Ø10 RAI Ø12 MTE Ø10 MTE Ø12	COM 1/100-05	RING
		MISURAI15+C	RAI Ø15 MTE Ø15	COM 1/100-05	RING
		MISURAI20-25+C	RAI Ø20 RAI Ø25 MTE Ø20 MTE Ø25	COM 1/100-05	ARM
		MISURAI30-35+C	RAI Ø30 RAI Ø35 MTE Ø30 MTE Ø35	COM 1/100-05	ARM
		MISURAI40-45+C	RAI Ø40 RAI Ø45 MTE Ø40 MTE Ø45	COM 1/100-05	ARM
		MISURAI50+C	RAI Ø50	COM 1/100-010	ARM

NOTE: TO ORDER THE DEVICE WITHOUT THE DIAL GAUGE OMIT + C (ES. MISURAI 10-12)

INSTRUCTIONS FOR MISURAI DEVICE

- 1_Mount the MISURAI on the RAI or MTE boring bars
- 2_Place the cap on the edge of the insert plate
- 3_Reset the gauge
- 4_Losen the locking grain (2) and the screw (3)
- 5_Change the diameter of reaming by rotating the adjusting grain (1) and reading the centesimal variation on the dial of the comparator
- 6_Awarded your size , first lock the screw (3) then the grain (2)
- 7_Remove the MISURAI: the boring tool is ready for use

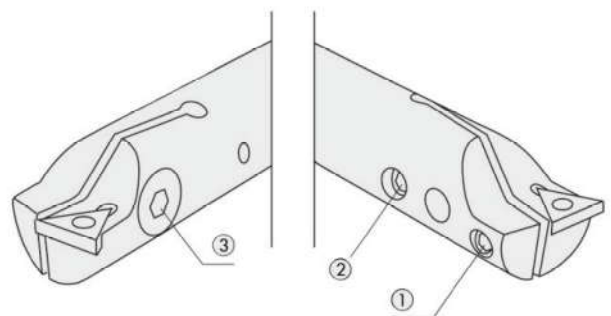

BORING BARS RAI & MTE SET

	CODE	QUANTITY	SET COMPOSITION
	SET RAI 6-25	1 OF EACH	RAI Ø6
			RAI Ø7
			RAI Ø8
			RAI Ø10
			RAI Ø12
			RAI Ø15
			RAI Ø20
			RAI Ø25
			KEYS SUPPLIED

	CODE	QUANTITY	SET COMPOSITION
	SET RAI 6-45	1 OF EACH	RAI Ø6
			RAI Ø7
			RAI Ø8
			RAI Ø10
			RAI Ø12
			RAI Ø15
			RAI Ø20
			RAI Ø25
			RAI Ø30
			RAI Ø35
			RAI Ø40
			RAI Ø45
			KEY INCLUDED

	CODE	QUANTITY	SET COMPOSITION
	SET MTE 10-45	1 OF EACH	MTE Ø10
			MTE Ø12
			MTE Ø15
			MTE Ø20
			MTE Ø25
			MTE Ø30
			MTE Ø35
			MTE Ø40
			MTE Ø45
			KEY INCLUDED

THE RAI BORING BARS ARE **PATENTED**

RAIMAX

ADJUSTABLE BORING HEAD FOR BORING Ø28-250

**INSUPERABLE FOR ROUGHING AND FINISHING OPERATIONS!
HIGH RIGIDITY LESS VIBRATIONS**



RAIMAX SYSTEM

ADJUSTABLE HEAD FOR BORING.
MOUNTABLE ON MILLING CUTTER HOLDER
CHUCKS COMMONLY AVAILABLE ON THE
MARKET

General Cutting Speed - Roughing -

VT= 180M

AZ= 0.15-1mm

Ap= 3-4mm Radius



RAIMAX



RAIMAX2

RAIMAX

ADJUSTABLE BORING HEAD FOR BORING Ø28-250

The adjustable head allows **RAIMAX** of boring and reaming operations. All heads have a lubrication hole. Adjustment of the cutting tool diameter it's obtained by rotation of a screw. The latter slides, radially to the axis of rotation of the head, a cartridge insert placed inside a U-shaped channel machined into the body of the tool. The head attachment allows you to mount the tool on the milling cutter holder chucks commonly available on the market. Centesimal adjustment of cutting diameter using the **MISURAIMAX** device consisting of arm, a perforated cylinder and a centesimal or millesimal dial gauge, upon request.



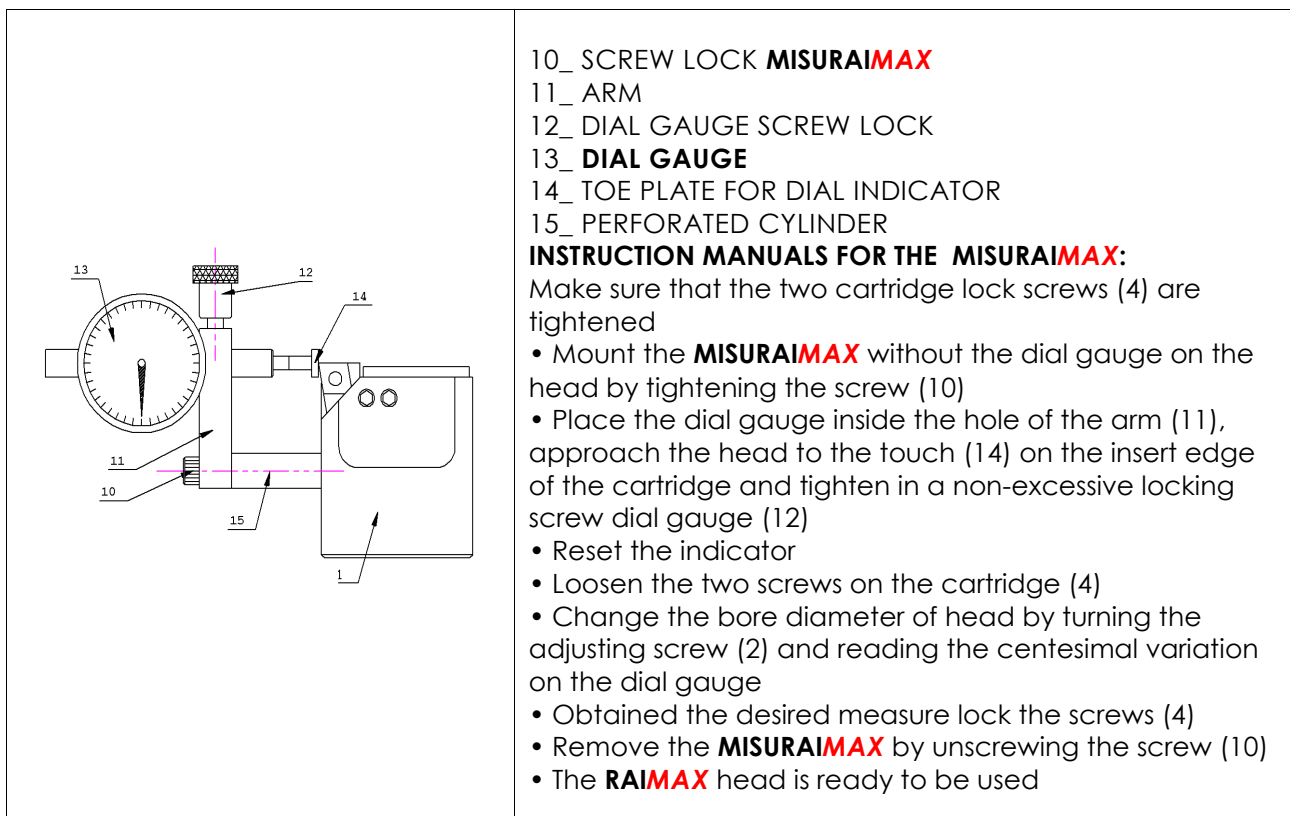
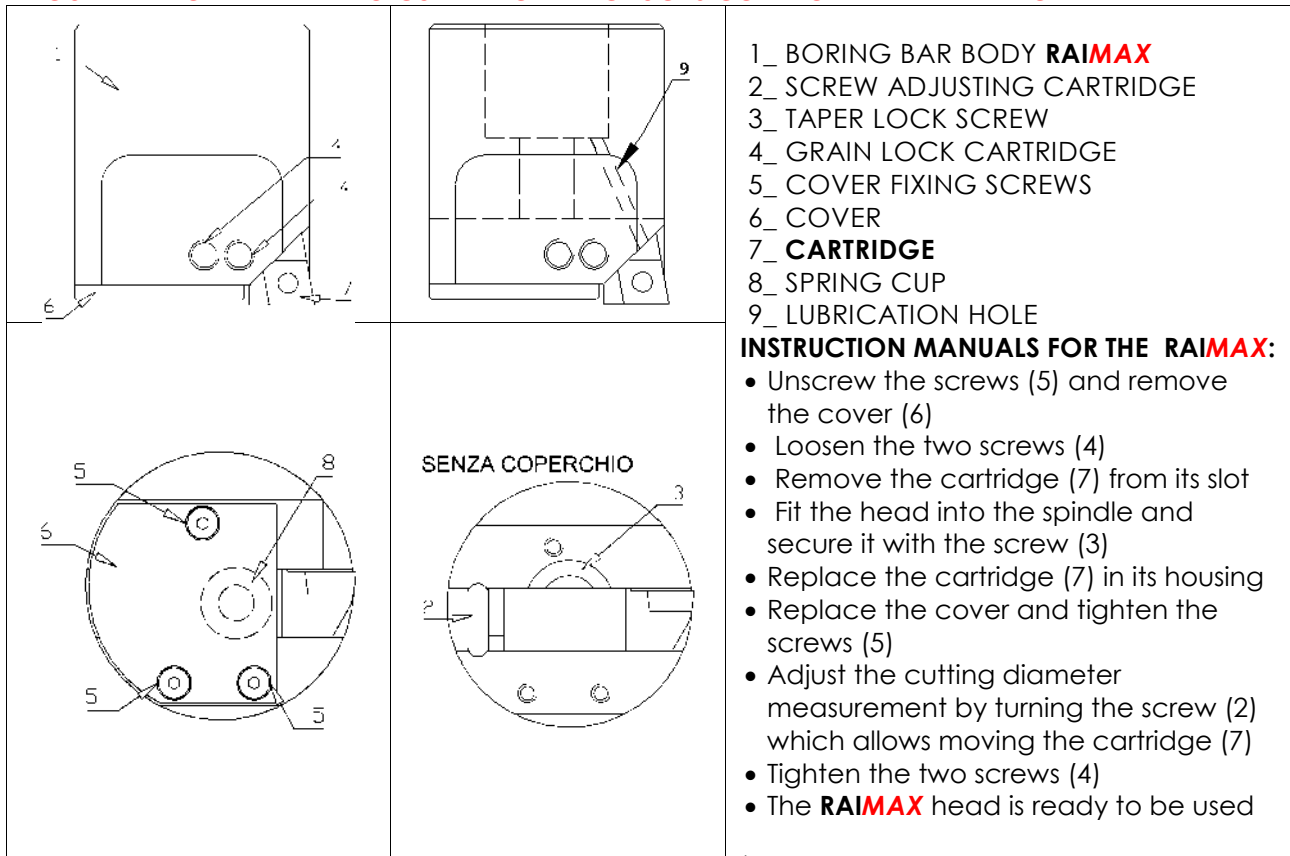

MOUNTABLE ON THE MILLING CUTTER HOLDER CHUCKS COMMONLY AVAILABLE ON THE MARKET





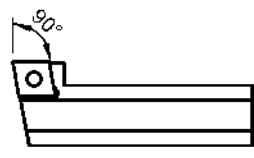

MOUNTABLE ON THE MILLING CUTTER HOLDER CHUCKS COMMONLY AVAILABLE ON THE MARKET

RAIMAX**ADJUSTABLE BORING HEAD
FOR BORING Ø28-250**

	CODE	BORING	D	L	USABLE CARTRIDGES		
	RAIMAX 30	28-40	16	45	SCGCL 08-06	STGPL 08-09	-
	RAIMAX 40	39-55	16	50	SCGCL 10-06	STGPL 10-09	-
	RAIMAX 50	49-75	22	56	SCGCL 12-09	STGPL 12-11	SSXCL 12-09
	RAIMAX 75	74-115	27	65	SCGCL 16-09	STGPL 16-11	SSXCL 16-09
	RAIMAX 100	98-160	40	67	SCGCL 20-09N	STGPL 20-11N	SSXCL 20-09N
	RAIMAX 150	148-250	40	67	SCGCL 20L-09N	STGPL 20L-11N	SSXCL 20L-09N

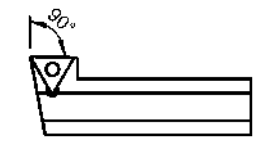
CODE CARTRIDGE SCGCL		INSERT		
	SCGCL 08-06	CC..0602	V28	TX7
	SCGCL 10-06			
	SCGCL 12-09	CC..09T3	V4C	TX15
	SCGCL 16-09			
	SCGCL 20-09N			
	SCGCL 20L-09N			

CODE CARTRIDGE STGPL		INSERT		
	STGPL 08-09	TP..0902	V28	TX7
	STGPL 10-09			
	STGPL 12-11	TP..1103	V10	TX9
	STGPL 16-11			
	STGPL 20-11N			
	STGPL 20L-11N			

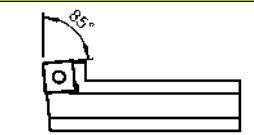
CODE CARTRIDGE SSXCL		INSERTO		
	SSXCL 12-09	SC..09T3	V4C	TX15
	SSXCL 16-09			
	SSXCL 20-09N			
	SSXCL 20L-09N			

SPARE PARTS



HEAD	LOCK SCREW CONE	COVER	N° COVER SCREW	ADJUSTABLE SCREW	2 x SCREW CARTRIDGE LOCK
RAIMAX 30	SR M 8 R/L	CC30	2 x VCC30	VR30	GG30
RAIMAX 40	SR M 8x20	CC40	3 x VCC40	VR40	GG40
RAIMAX 50	SR M10x20	CC50	3 x VCC50	VR50	GG50
RAIMAX 75	SR M12x25	CC75	4 x VCC75	VR75	GG75
RAIMAX 100	SR M20X	CC100	4 x VCC100	VR100N	GG100
RAIMAX 150	SR M20X	CC150	4 x VCC150	VR150N	GG150

ADJUSTING DEVICE - ON REQUEST IS ALSO AVAILABLE THE DIAL MILLESIMAL GAUGE

CODE	HEAD	COMPOSITION	
MISURAIMAX 30-40+C	RAIMAX 30	MISURAIMAX 30-40	DIAL GAUGE 1/100-05 #
	RAIMAX 40		
MISURAIMAX 50+C	RAIMAX 50	MISURAIMAX 50	DIAL GAUGE 1/100-010#
MISURAIMAX 75+C	RAIMAX 75	MISURAIMAX 75	DIAL GAUGE 1/100-010#
MISURAIMAX 100+C	RAIMAX 100	MISURAIMAX 100	DIAL GAUGE 1/100-010#
MISURAIMAX 150+C	RAIMAX 150	MISURAIMAX 150	DIAL GAUGE 1/100-010#

RAIMAX & MISURAIMAX ARE PATENTED PRODUCTSNOTE: TO ORDER THE DEVICE WITHOUT THE DIAL GAUGE OMIT + C (ES. **MISURAIMAX** 30-40)

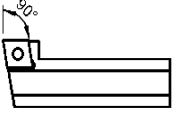
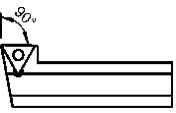
RAIMAX SET

CARTRIDGE	INSERT	SET WITH 1 CARTRIDGE	COMPOSITION	
 SCGCL	CC..0602	SET RAIMAX 30 SC	1 HEAD RAIMAX 30 1 CARTRIDGE SCGCL 08-06 1 MISURAIMAX 30-40 + DIAL GAUGE 1/100-05	
		SET RAIMAX 40 SC	1 HEAD RAIMAX 40 1 CARTRIDGE SCGCL 10-06 1 MISURAIMAX 30-40 + DIAL GAUGE 1/100-05	
	CC..09T3	SET RAIMAX 50 SC	1 HEAD RAIMAX 50 1 CARTRIDGE SCGCL 12-09 1 MISURAIMAX 50 + DIAL GAUGE 1/100-010	
		SET RAIMAX 75 SC	1 HEAD RAIMAX 75 1 CARTRIDGE SCGCL 16-09 1 MISURAIMAX 75 + DIAL GAUGE 1/100-010	
		SET RAIMAX 100 SC	1 HEAD RAIMAX 100 1 CARTRIDGE SCGCL 20-09 1 MISURAIMAX 100 + C DIAL GAUGE 1/100-010	
		SET RAIMAX 150 SC	1 HEAD RAIMAX 150 1 CARTRIDGE SCGCL 20L-09 1 MISURAIMAX 150 + DIAL GAUGE 1/100-010	
	 STGPL	TP..0902	SET RAIMAX 30 ST	1 HEAD RAIMAX 30 1 CARTRIDGE STGPL 08-09 1 MISURAIMAX 30-40 + DIAL GAUGE 1/100-05
			SET RAIMAX 40 ST	1 HEAD RAIMAX 40 1 CARTRIDGE STGPL 10-09 1 MISURAIMAX 30-40 + DIAL GAUGE 1/100-05
TP..1103		SET RAIMAX 50 ST	1 HEAD RAIMAX 50 1 CARTRIDGE STGPL 12-11 1 MISURAIMAX 50 + DIAL GAUGE 1/100-010	
		SET RAIMAX 75 ST	1 HEAD RAIMAX 75 1 CARTRIDGE STGPL 16-11 1 MISURAIMAX 75 + DIAL GAUGE 1/100-010	
		SET RAIMAX 100 ST	1 HEAD RAIMAX 100 1 CARTRIDGE STGPL 20-11 1 MISURAIMAX 100 + DIAL GAUGE 1/100-010	
		SET RAIMAX 150 ST	1 HEAD RAIMAX 150 1 CARTRIDGE STGPL 20L-11 1 MISURAIMAX 150 + DIAL GAUGE 1/100-010	
 SSXCL		SC..09T3	SET RAIMAX 50 SS	1 HEAD RAIMAX 50 1 CARTRIDGE SSXCL 12-09 1 MISURAIMAX 50 + DIAL GAUGE 1/100-010
			SET RAIMAX 75 SS	1 HEAD RAIMAX 75 1 CARTRIDGE SSXCL 16-09 1 MISURAIMAX 75 + DIAL GAUGE 1/100-010
	SET RAIMAX 100 SS		1 HEAD RAIMAX 100 1 CARTRIDGE SSXCL 20-09 1 MISURAIMAX 100 + DIAL GAUGE 1/100-010	
	SET RAIMAX 150 SS		1 HEAD RAIMAX 150 1 CARTRIDGE SSXCL 20L-09 1 MISURAIMAX 150 + DIAL GAUGE 1/100-010	

COMPLETE RAIMAX SET

COMPLETE RAIMAX SET	COMPOSITION
SET RAIMAX 30 A	1 HEAD RAIMAX 30 2 CARTRIDGES: SCGCL 08-06 / STGPL 08-09 1 MISURAIMAX 30-40 + DIAL GAUGE 1/100-05
SET RAIMAX 40 A	1 HEAD RAIMAX 40 2 CARTRIDGES: SCGCL 10-06 / STGPL 10-09 1 MISURAIMAX 30-40 + DIAL GAUGE 1/100-05
SET RAIMAX 50 A	1 HEAD RAIMAX 50 3 CARTRIDGES: SCGCL 12-09 / STGPL 12-11 / SSXCL 12-09 1 MISURAIMAX 50 + DIAL GAUGE 1/100-010
SET RAIMAX 75 A	1 HEAD RAIMAX 75 3 CARTRIDGES: SCGCL 16-09 / STGPL 16-11 / SSXCL 16-09 1 MISURAIMAX 75 + DIAL GAUGE 1/100-010
SET RAIMAX 100 A	1 HEAD RAIMAX 100 3 CARTRIDGES: SCGCL 20-09 / STGPL 20-11 / SSXCL 20-09 1 MISURAIMAX 100 + DIAL GAUGE 1/100-010
SET RAIMAX 150 A	1 HEAD RAIMAX 150 3 CARTRIDGES: SCGCL 20L-09 / STGPL 20L-11 / SSXCL 20L-09 1 MISURAIMAX 150 + DIAL GAUGE 1/100-010

RAIMAX2

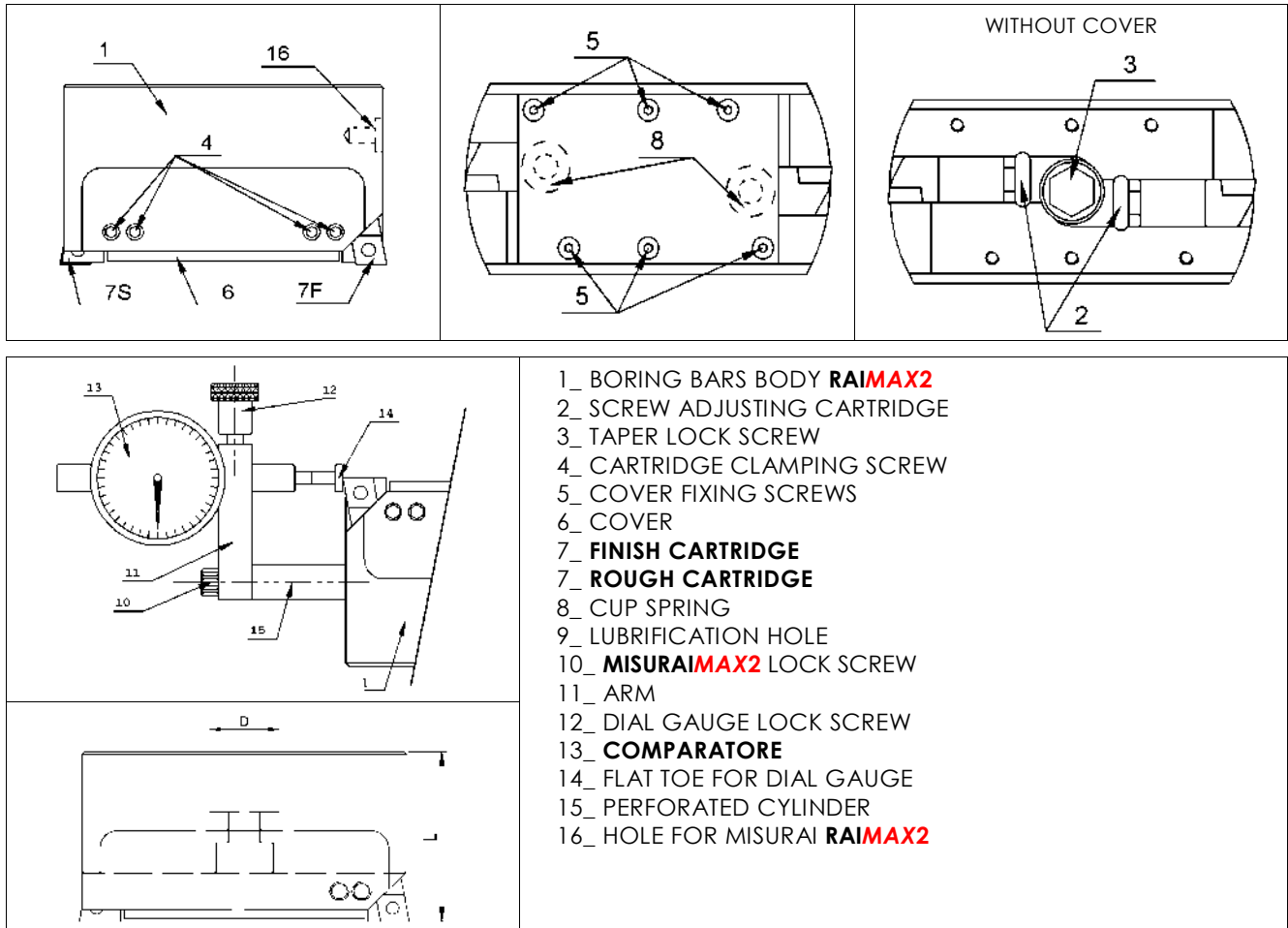

ADJUSTABLE BORING HEAD FOR BORING Ø148-250

MOUNTABLE ON THE MILLING CUTTER HOLDER CHUCKS COMMONLY COMMERCIALY AVAILABLE WITH TWIN CARTRIDGE ROUGH-FINISH



- 1_ BORING BARS BODY **RAIMAX2**
- 2_ SCREW ADJUSTING CARTRIDGE
- 3_ TAPER LOCK SCREW
- 4_ CARTRIDGE CLAMPING SCREW
- 5_ COVER FIXING SCREWS
- 6_ COVER
- 7_ **FINISH CARTRIDGE**
- 7_ **ROUGH CARTRIDGE**
- 8_ CUP SPRING
- 9_ LUBRIFICATION HOLE
- 10_ **MISURAIMAX2** LOCK SCREW
- 11_ ARM
- 12_ DIAL GAUGE LOCK SCREW
- 13_ **COMPARATORE**
- 14_ FLAT TOE FOR DIAL GAUGE
- 15_ PERFORATED CYLINDER
- 16_ HOLE FOR MISURAI **RAIMAX2**

HEAD	BORING	D	L	FINISH CARTRIDGE			ROUGH CARTRIDGE	
RAIMAX2 150	148-200	40	67	SCGCL 20F-09	STGPL 20F-11	SSXCL 20F-09	SCGCL 20S-09	SSXCL 20S-09
RAIMAX2 200	198-250	40	67					

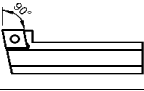
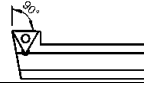
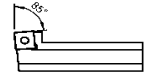
CODE		INSERT		
	SCGCL 20F-09	CC..09T3	V4C	TX15
	SCGCL 20S-09			
	STGPL 20F-11	TP..1103	V10	TX9
	SSXCL 20F-09	SC..09T3	V4C	TX15
	SSXCL 20S-09			

HEAD	LOCK SCREW CONE	COVER	4 x COVER SCREW	2 x ADJUSTMENT SCREW.	4 x CARTRIDGE SCREW LOCK
RAIMAX2 150	SR M20X	CC150-DP	VCC150	VR150-DP	GG150
RAIMAX2 200	SR M20X	CC200-DP	VCC200	VR200-DP	GG200

ADJUSTING DEVICE - ON REQUEST IS ALSO AVAILABLE MILLESIMAL DUAL GAUGE

CODE	HEAD	COMPOSITION	
MISURAIMAX2 150 200+C	RAIMAX2 150	MISURAIMAX2 150-200	DIAL GAUGE 1/100-010*
	RAIMAX2 200		

NOTE: TO ORDER THE DEVICE WITHOUT THE DIAL GAUGE OMIT + C
ES. 150-200 **MISURAIMAX2**

RAIMAX2 SET

HEAD + 2 CARTRIDGES (ROUGH & FINISH) + MISURAIMAX2 + DIAL GAUGE

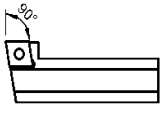
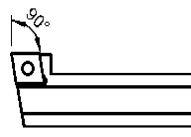
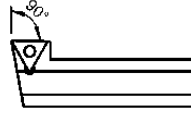
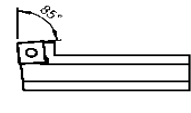
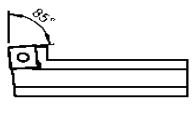
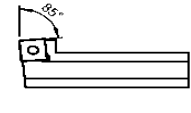
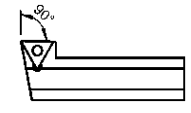
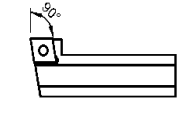
ROUGH	FINISH	SET RAIMAX2	COMPOSITION
 SCGCL 20S-09 (CC..09T3)	 SCGCL 20F-09 (CC..09T3)	SET RAIMAX2 150 1	1 HEAD RAIMAX2 150 1 ROUGH CARTRIDGE SCGCL 20S-09 1 FINISH CARTRIDGE SCGCL 20F-09 1 MISURAIMAX2 150-200 1 DIAL GAUGE 1/100-010
		SET RAIMAX2 200 1	1 HEAD RAIMAX2 200 1 ROUGH CARTRIDGE SCGCL 20S-09 1 FINISH CARTRIDGE SCGCL 20F-09 1 M MISURAIMAX2 150-200 1 DIAL GAUGE 1/100-010
	 STGPL 20F-11 (TPGX 1103)	SET RAIMAX2 150 2	1 HEAD RAIMAX2 150 1 ROUGH CARTRIDGE SCGCL 20S-09 1 FINISH CARTRIDGE STGPL 20F-11 1 MISURAIMAX2 150-200 1 DIAL GAUGE 1/100-010
		SET RAIMAX2 200 2	1 HEAD RAIMAX2 200 1 ROUGH CARTRIDGE SCGCL 20S-09 1 FINISH CARTRIDGE STGPL 20F-11 1 MISURAIMAX2 150-200 1 DIAL GAUGE 1/100-010
	 SSXCL 20F-09 (SC..09T3)	SET RAIMAX2 150 3	1 HEAD RAIMAX2 150 1 ROUGH CARTRIDGE SCGCL 20S-09 1 FINISH CARTRIDGE SSXCL 20F-09 1 MISURAIMAX2 150-200 1 DIAL GAUGE 1/100-010
		SET RAIMAX2 200 3	1 HEAD RAIMAX2 200 1 ROUGH CARTRIDGE SCGCL 20S-09 1 FINISH CARTRIDGE SSXCL 20F-09 1 MISURAIMAX2 150-200 1 DIAL GAUGE 1/100-010
 SSXCL 20S-09 (SC..09T3)	 SSXCL 20F-09 (SC..09T3)	SET RAIMAX2 150 4	1 HEAD RAIMAX2 150 1 ROUGH CARTRIDGE SSXCL 20S-09 1 FINISH CARTRIDGE SSXCL 20F-09 1 MISURAIMAX2 150-200 1 COMPARATORE 1/100-010
		SET RAIMAX2 200 4	1 HEAD RAIMAX2 200 1 ROUGH CARTRIDGE SSXCL 20S-09 1 FINISH CARTRIDGE SSXCL 20F-09 1 MISURAIMAX2 150-200 1 DIAL GAUGE 1/100-010
	 STGPL 20F-11 (TPGX 1103)	SET RAIMAX2 150 5	1 HEAD RAIMAX2 150 1 ROUGH CARTRIDGE SSXCL 20S-09 1 FINISH CARTRIDGE STGPL 20F-11 1 MISURAIMAX2 150-200 1 DIAL GAUGE 1/100-010
		SET RAIMAX2 200 5	1 HEAD RAIMAX2 200 1 ROUGH CARTRIDGE SSXCL 20S-09 1 FINISH CARTRIDGE STGPL 20F-11 1 MISURAIMAX2 150-200 1 DIAL GAUGE 1/100-010
	 SCGCL 20F-09 (CC..09T3)	SET RAIMAX2 150 6	1 HEAD RAIMAX2 150 1 ROUGH CARTRIDGE SSXCL 20S-09 1 FINISH CARTRIDGE SCGCL 20F-09 1 MISURAIMAX2 150-200 1 DIAL GAUGE 1/100-010
		SET RAIMAX2 200 6	1 HEAD RAIMAX2 200 1 ROUGH CARTRIDGE SSXCL 20S-09 1 FINISH CARTRIDGE SCGCL 20F-09 1 MISURAIMAX2 150-200 1 DIAL GAUGE 1/100-010



Nuova C.U.M.E.T. Srl

Via Torino, 502 - 10032 Brandizzo (TO) ITALY

Tel: +39 011 917 95 14/15

Telefax: +39 011 917 95 55/02

www.nuovacumet.it • info@nuovacumet.it

B.A. Machinery

Beijing

Tel: (86)-10-63777466/76

Telefax: (86)-10-63777486

www.nuovacumet.cn • info@nuovacumet.cn

CUMET Tools S.r.o.

Vilová 298/1746010

Liberec 10

GSM: +420-602 232 383

www.cumet.cz - zuda@cumet.cz

DAES Logistic Inc.

2309 New Forest Court

Arlington, TX 76017

Tel: 001-817-7846246

www.dassaero.com